

JP3.0 Ribbon Tweeter

- SSS I recommends a of 3rd order filter between 3.7K to 9Khz
- Large Alloy ribbon heatsink assy
- Shielded neo magnetic structure ensures home theatre applications in medium powered systems
- Effective from 2000 Hz upwards due to the large diaphragm area and low self-resonance.
- Extremely thin diaphragm (0.009mm Aluminum foil) weighing 15mg in mass gives extreme speed and transient response with detail and a wide dynamic range
- low level detail
- High efficiency is guaranteed by the double neodymium boron magnets.
- Very Low distortion factor, good power-handling capabilities, highly linear impedance and amplitude frequency response with wide frequency response range make this suitable for any high end sound system
- High definition wide bandwidth rear mounted matching transformer couples the alloy ribbon diaphragm to impedance match for a nominal 7.5 ohms ac resistance at 1Khz and constant to 20Khz where it reaches 8.2 ohm making this an excellent load for crossover designs with minium phase variations

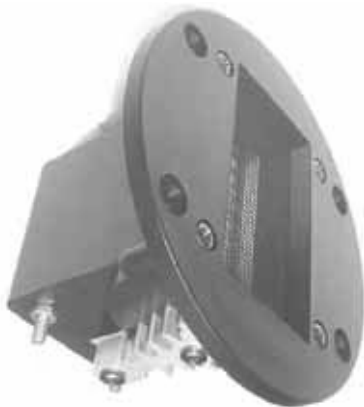

Specifications



Mechanical Drawing

Round Face ribbon 110mm diameter for flush mounting into speaker baffle

STONES SOUND STUDIO

PR3.0 Ribbon Tweeter

Application Notes.
NOV 2003 Revision 1

by Russell Storey Stones Sound Studio

Ribbon V/S Dome tweeter

The Pr3.0 Ribbon tweeter is completely different to a conventional anular coil driver dome tweeter in its characteristics and should to be treated with care because of the wide bandwidth fragile low mass diaphragm and impedance matching transformer .

Power Rating

Applied power to the ribbon should be limited by careful Xover design for the particular application be it a 2way or 3way Xover as this ribbon has a built in transformer with a primary impedance of 4ohms (ac) 0.2 ohms DC . So this can act as a short circuit to an amplifier below Xover frequencies of 1 KHz

Because of the ribbons low mass diaphragm (11mg) they are susceptible to low frequency damage below 1Khz and I recommend should be normally operated at frequencies above 3khz in any speaker system . The tweeter has a rating of 15watts RMS sine wave at 3 kHz or 100 watts with music program material with a professionally designed crossover over a limited period of time. This is a very efficient tweeter so it does not require a lot of power to achieve high SPL sound levels.

Bandwidth

Because of the PR3.0 ribbon tweeter wide bandwidth to 40 KHz the crossover type is very important.

The use High Quality wide bandwidth Audio components are necessary to hear the benefits of a ribbon tweeter. Use HQ interconnects / Speaker leads/Speakers /Home theatre amplifiers / SACD /DVD players. I recommend professionally designed crossovers using Audio high grade capacitors non inductive resistors and coils to achieve the optimum performance from this excellent ribbon tweeter.

Xover Filters for the Ribbon tweeter

If a simple 6 db/octave filter (single capacitor in series with the ribbon) is used below frequencies of 5Khz KHz low frequencies can damage the ribbon diaphragm.

6db/Filter Single Capacitor 3way speaker systems

I recommend that the tweeter is used above 7.8Khz as a super tweeter in a 3way speaker system with a 2.2uf /400V metalized polypropylene .

12bd/18db/Filter Xover for 2 and 3 Way speaker systems

For lower Xover frequencies in the range from 3 to 7.8KHz KHz the ribbon requires a minimum of a 2nd 12bd/oct or 3rd order 18db/octave high pass filter design which I have developed specifically for the PR3.0 ribbon tweeter for general applications .

A 3rd order Xover was custom designed and developed by Stones Sound Studio using the LEAP Professional Crossover Program to optimize the high quality and power bandwidth of this ribbon.

Regards
Russell Storey

Ribbon Material	100% Aluminum
-----------------	---------------

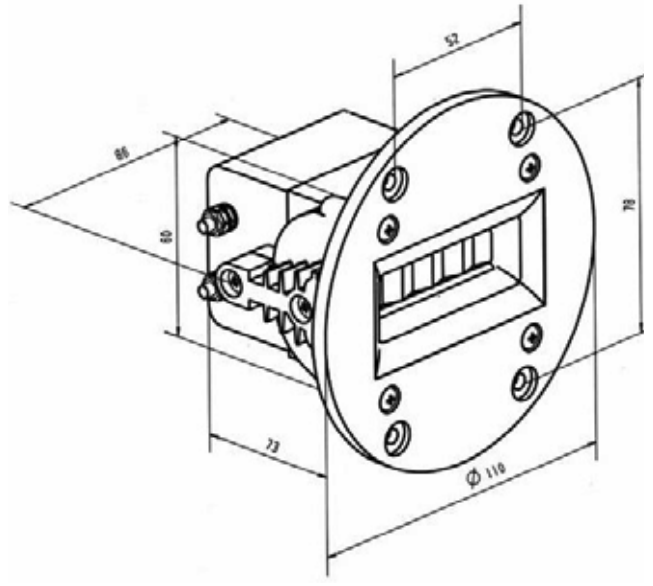

STONES SOUND STUDIO

Jp3.0 Ribbon Crossover

(18db/oct @ 4khz 0db)

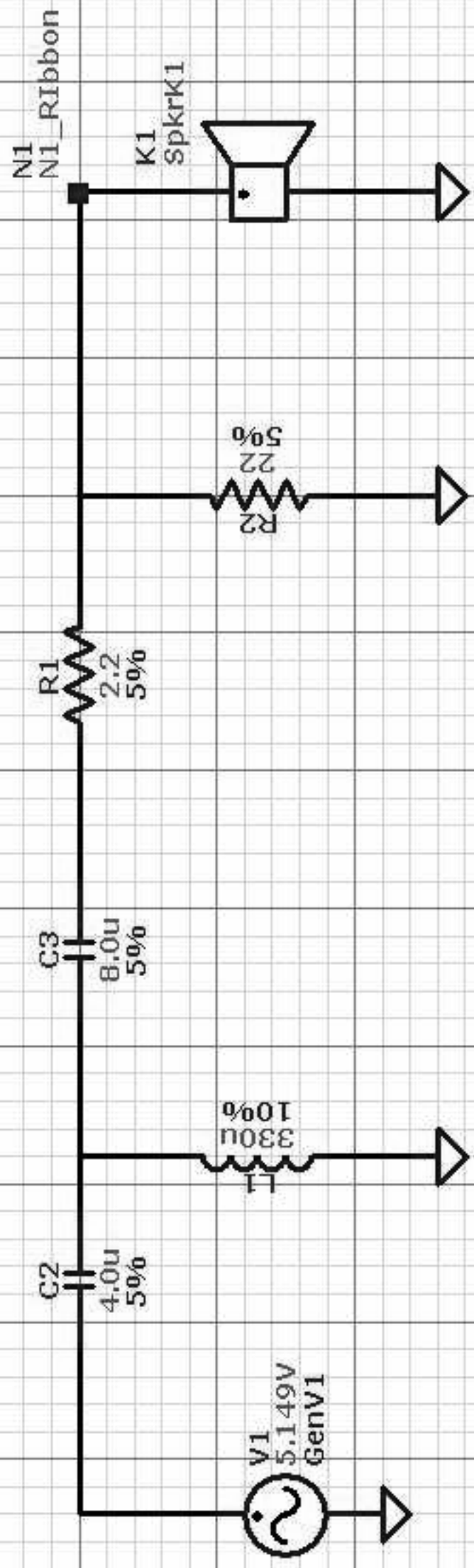

STONES SOUND STUDIO

Jp3.0 Ribbon Crossover

(18db/oct @ 4kHz -3db)

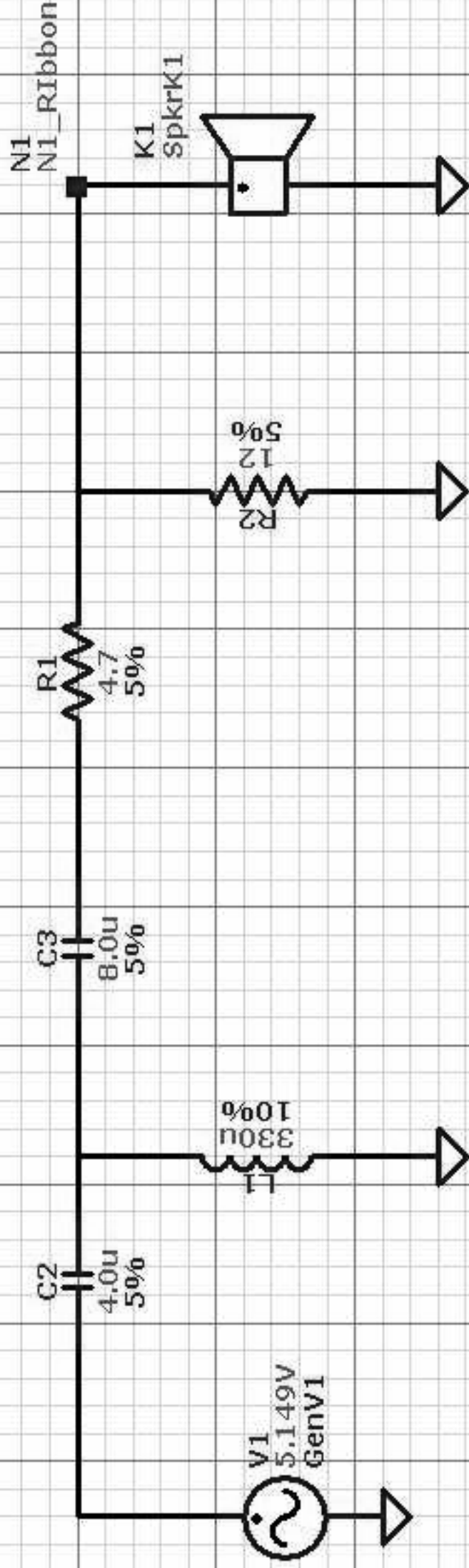

STONES SOUND STUDIO

Jp3.0 Ribbon Crossover

(18db/oct @ 4khz -4db)

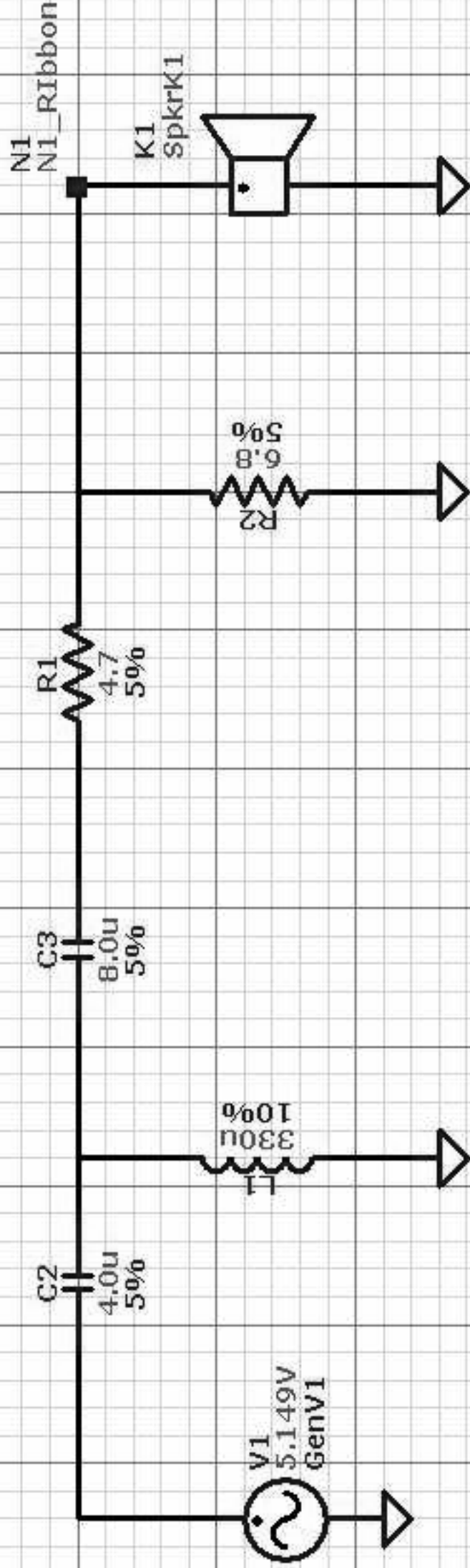

STONES SOUND STUDIO Jp3.0 Ribbon Crossover (18db/oct @ 4khz -5db)

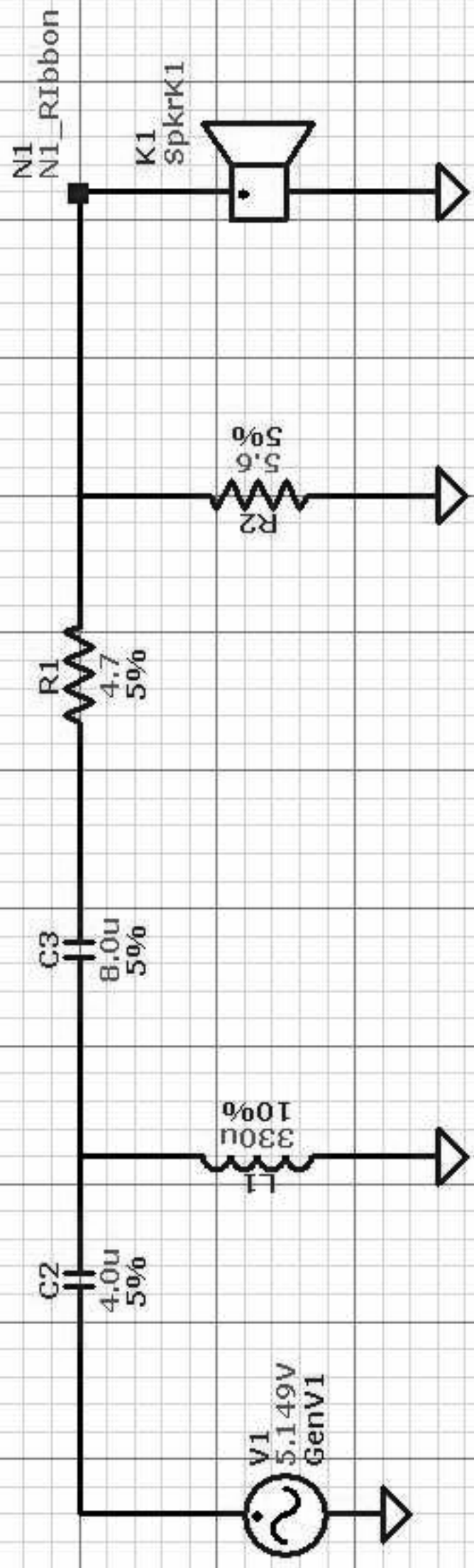

STONES SOUND STUDIO Jp3.0 Ribbon Crossover (18db/oct @ 4khz -6dbb)

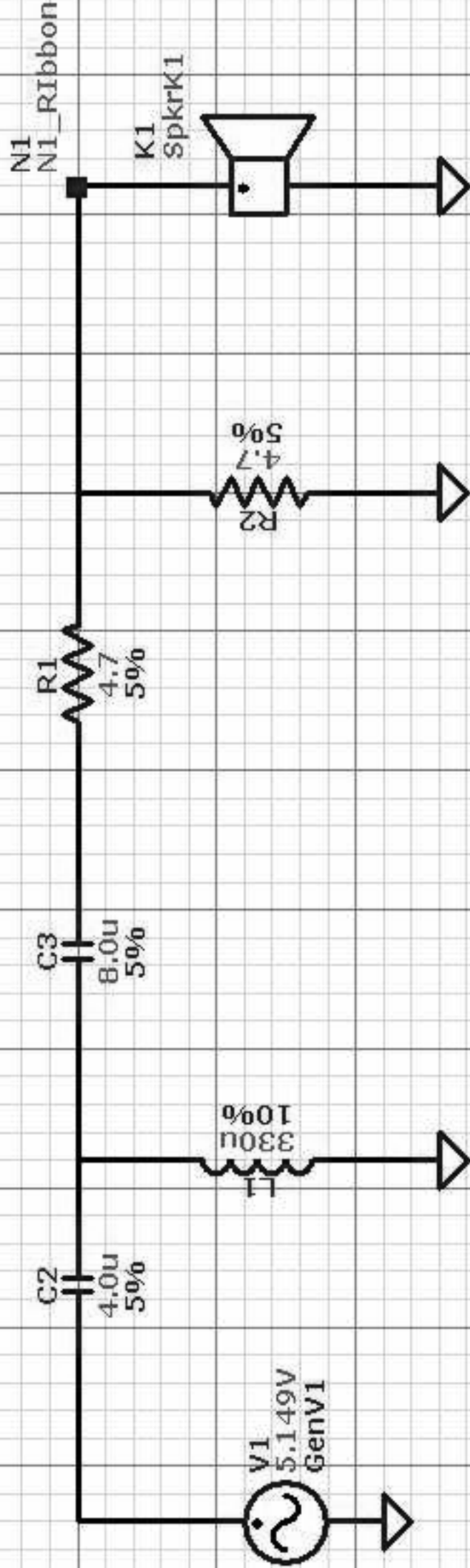

SPL vs Freq

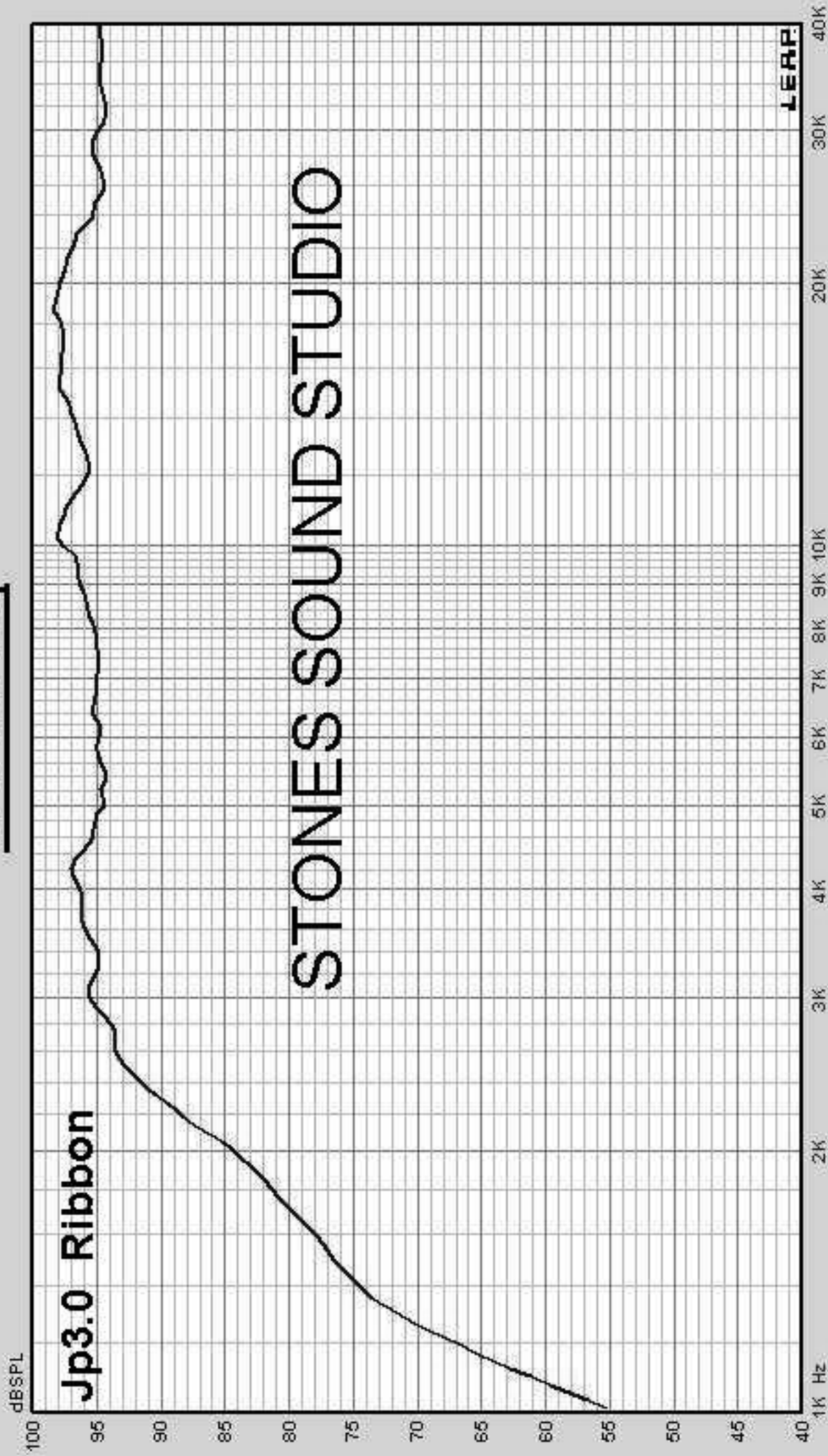

4: SPL@1M,0H,0V SpkrK1
5: SPL@1M,0H,0V Sum(C)

Impedance vs Freq

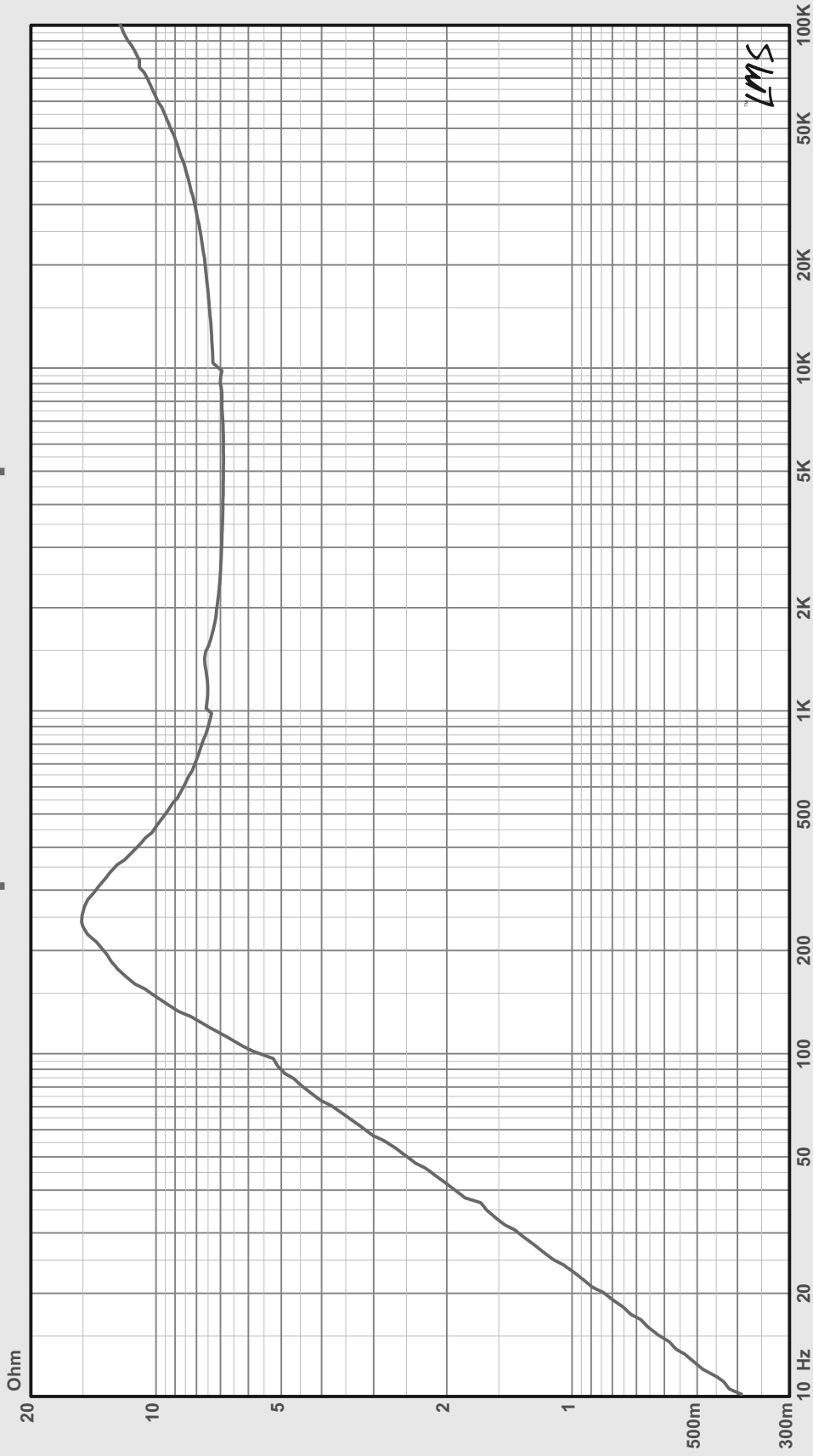

— 11: POLY RIBBON-100K

Map

MEASURED WITH LMS

Notes

Constant Impedance from 1K to 20K 7.5 ohm to 8.5 ohm

Delta R Z 1 ohm No bad Jim

LMS

4.5.0.340
May/30/2003

Person: RUSSELL STOREY
Company: STONES SOUND STUDIO

Project: POLY 3.0 RIBBON TRANSDUCER
File: POLY-3.LIB

Aug 20, 2003
Wed 4:49 pm

LINEAR X
S Y S T E M S

Impedance vs Freq

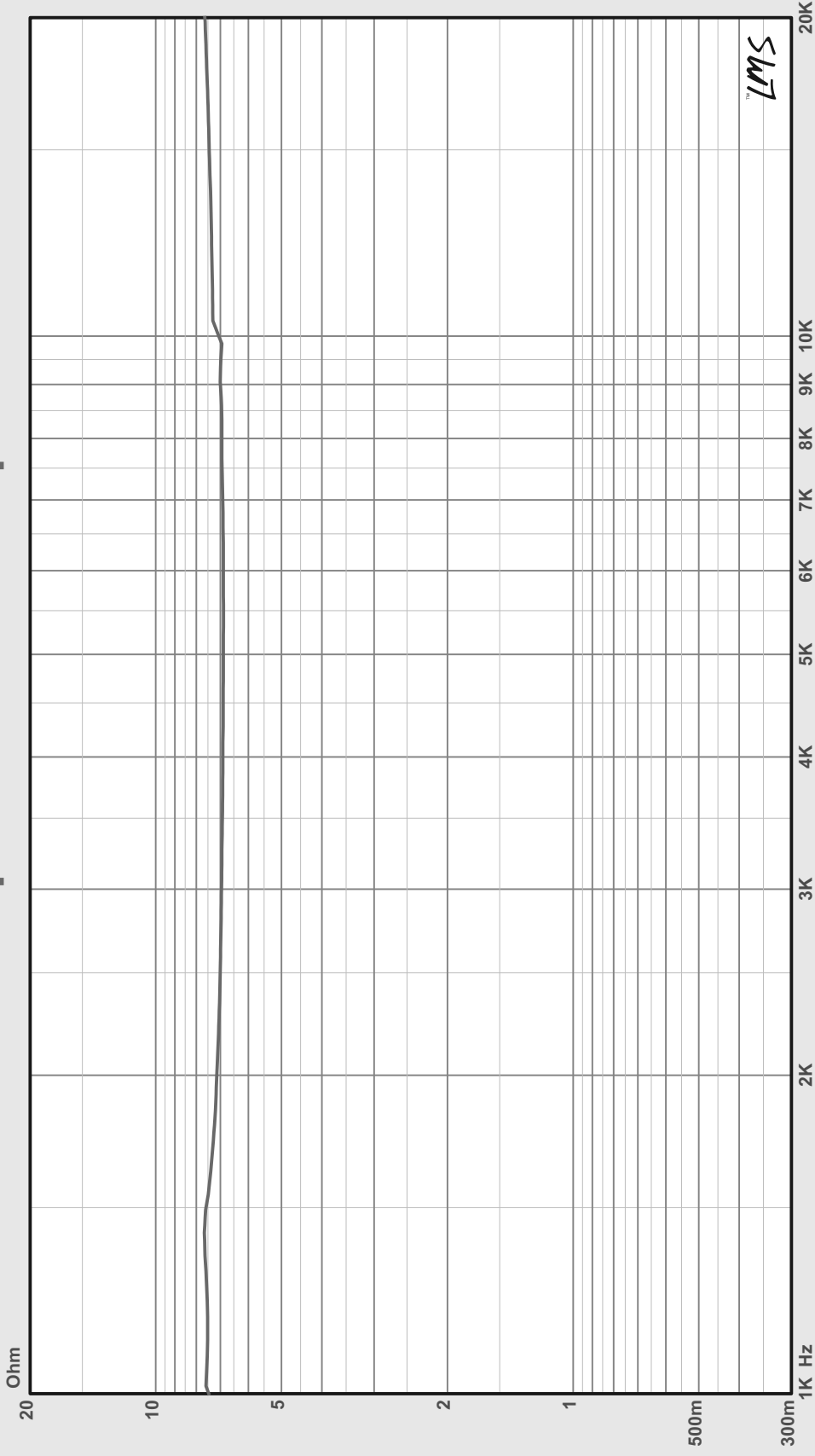

— 11: POLY RIBBON-100K

Map

MEASURED WITH LMS

Notes

Constant Impedance from 1K to 20K 7.5 ohm to 8.5 ohm
Delta R Z 1 ohm No bad Jim

4.5.0.340
May/30/2003

Person: RUSSELL STOREY
Company: STONES SOUND STUDIO

Project: POLY 3.0 RIBBON TRANSDUCER
File: POLY-3.LIB

Aug 20, 2003
Wed 4:51 pm

LINEAR
S Y S T E M S

LMS

STONES SOUND STUDIO

ARTISAN JP3.0 RIBBON CROSSOVER

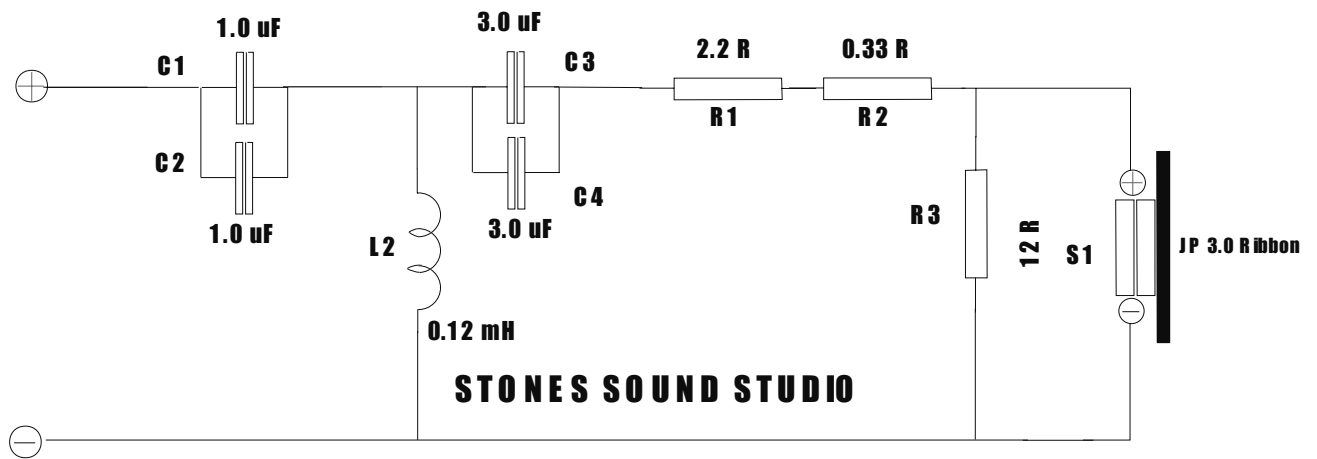

REVISION (1) NOV-2003

Stones Sound Studio

ARTISAN JP 3.0 RIBBON XOVER

Designed by **Russell Storey**

Date **NOV 2003**

Audiophile Speaker Xover

DWG No
PR3-008

COMPONENTS

L1 = 0.12 mH

C1/C2 = 1uF

C3/C4 = 3.0uF

R1 = 2.2 R 10W

R2 = 0.33R 10W

R3 = 12 R 10W

S1 = JP 3.0 Ribbon Tweeter



Locked Bag 30
138 Liverpool Rd
Ashfield 2131

QUALITY
PRODUCTS and
ACCESSORIES



FOUNTEK RIBBON TWEETER SOLD IN MATCHED PAIRS

Features

High-pressure injection molded 5mm faceplate.
Pure Aluminum ribbon (not a metalised film type).
Super strong Neodymium magnet for high efficiency.
Built-in Impedance conversion transformer
Incredibly flat impedance for easy crossover design.
Effective from 1,700 Hz upwards due to the large diaphragm area and low self-resonance.
Extremely thin diaphragm (0.009mm Aluminum foil) best for a High degree of signal fidelity and broad frequency response.
Only 11mg mass for instantaneous signal response and micro-detail.
Low distortion factor, good power-handling capabilities, highly linear impedance and amplitude frequency response and broad frequency response range. Flat impedance curve from 1KHz to 40KHz.
Individually factory tested and assessed then paired for efficiency and response matching.
Very competitively priced for this level of technology.
Upgrade to the ultra high frequency response of todays equipment.

**EXCLUSIVE!
SUPER LOW
PRICE PAIR!**



Shielded

110mm
Diam.

PURE RIBBON TRANSDUCER - 2KHz → OVER 40KHz!

World renowned as one of the best high-end loudspeaker drivers available. This technology is based on the use of a pure aluminium ribbon element suspended in a high flux magnetic field. This diaphragm weighs 30x less and has a surface area 10 times larger than a conventional dome tweeter. The specifications and sound quality is the next step up in performance offering instantaneous signal reproduction, rarely heard micro-detail with exquisitely fast decay times. This translates into incredible realism. A built-in coupling transformer is used to match the impedance giving a very smooth response for easy crossover design and minimal phase errors. This tweeter is sold in factory tested matched pairs. Buy 1 to receive 2.

Ribbon 11mg 480mm² Al.
TX 6 ohm nominal (DC=0.01 ohm)
Sens 96dB (2.83V/1M)
Power 14Wrms (Max 40W)
Pair JP30
Sold in matched pairs only.

**PURE
AUDIOPHILE
HI FI**

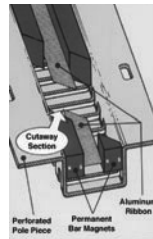

SOLD IN MATCHED PAIRS ONLY

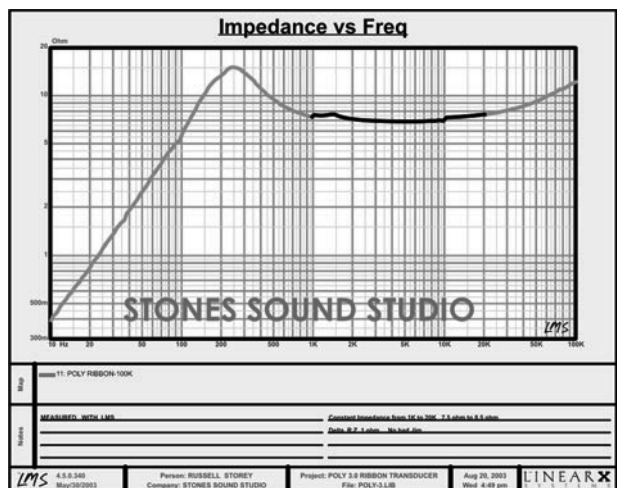
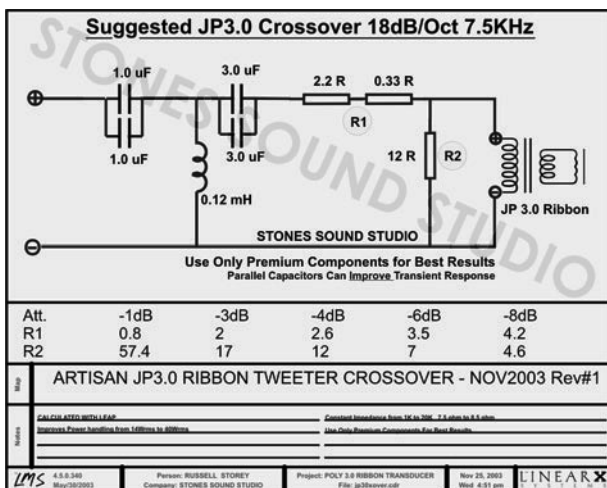
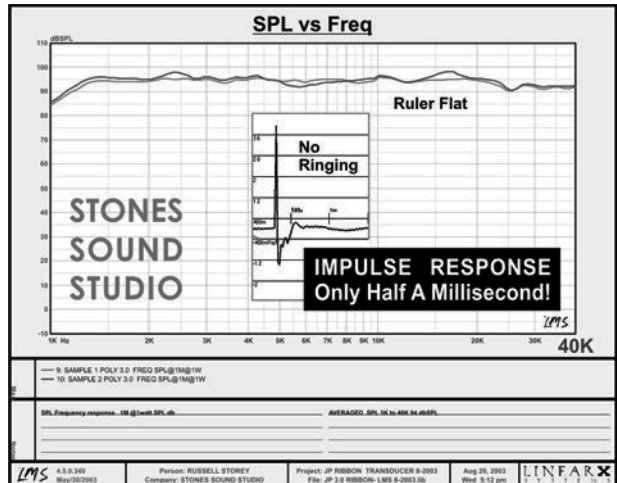
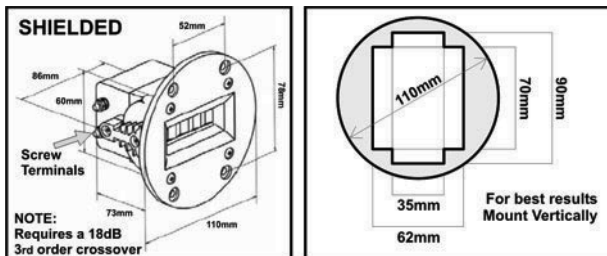

Stone Sound Studio is an independent Audio Assessment company.