

HDS-250 MTM SPEAKERS

The HDS250 audiophile, high definition speaker is designed to faithfully reproduce both music and home cinema sound with crystal clear and pinpoint imaging. Best suited for use in small to medium sized rooms on speaker stands or a shelf. This exceptional speaker was developed to work in both the vertical and horizontal axis and uses shielded drivers for use near TVs, with home theater systems in any of the required positions (front/rear/center). A special version (HDS250C) is available for the center channel, developed with extra attention given to vocal clarity required by cinema. Two 5.5" Peerless HDS mid-woofers give articulate tight, fast bass, natural mids, an impressively wide sound stage with low distortion at even high volume levels. The purpose developed Peerless HDS tweeter is Time-Alligned (physically counter-sunk into the box) and Phase-aligned in an MTM coaxial design with a premium quality, professionally tuned box for incredible clarity, definition, accuracy and fantastic dynamic impact that rivals any speaker in this sized package. A truly audiophile speaker for music and/or home theater. Highly recommended to be used with our Peerless HDS255C center and XLS800 or XLS1000 subwoofers to complete the audio-visual experience.

danish sound technology

Australian
Made Boxes
With Danish
Speakers

Big sound from a compact box.
Fully Shielded for TV Home Theater.
Impressive Hi-Fi System Upgrade
Excellent for matching with our
8" or 12" Subwoofer Systems.
Speaker Stand or shelf mounted.
Rear vented. Tapered internal edges.
Time corrected, counter-sunk tweeter.
Coaxial MTM design. Curved grills.
Frequency 42Hz to 22KHz
H495 x W180 x D305mm
Power Amp 10 to 100 Watt
8ohm nominal
Sensitivity 92db



STANDS NOT INCLUDED



**AUSTRALIAN
DISTRIBUTOR**

WES COMPONENTS Aust Asia

**ALL
NEW**

enquiries@wescomponents.com Phone (02)9797-9866 Fax1 (02)9716-6015 Fax2 (02)9799-7051

HDS-250 MTM SPEAKERS

Peerless

danish sound technology



Big sound from a compact box.
Fully Shielded for TV Home Theater.
Use as Main, Center & Surround !
Impressive Hi-Fi System Upgrade.
Focussed clarity of time alignment.
Speaker Stand or shelf mounted.
Rear vented. Tapered internal edges.
Time corrected, counter-sunk tweeter.
Coaxial MTM design. Curved grills.
Cast alloy framed, 5 layered drivers,
the latest from Peerless Denmark.
Professionally designed and crafted.
Australian wood veneers.
Frequency 42Hz to 22KHz
H495 x W180 x D305mm
Power Amp 10 to 100 Watt
8ohm nominal. Sensitivity 92dB.
Excellent for matching with our
8" or 12" Subwoofer Systems.



HDS250C

HDS Home Theater

HDS455

**Sold As Single Units
Requires 2 for Stereo**



**Only premium quality
components are used**

HDS250 COMPLETE KIT

Sold Individually, Singular,
Two required for stereo.
Requires Assembly.

KIT250TO Tasmanian Oak
KIT250JA Jarah
KIT250BV Black Vinyl

Includes:

Built Cabinet with Speaker Grill
5" Mid-Woofers 850528 x2
1" Tweeter 810653
Crossover Kit (Requires Construction)
Assembly Hardware & Instructions

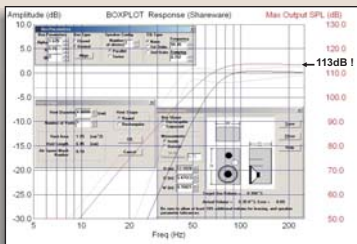

PEERLESS HDS/XLS SERIES OF SPEAKER SYSTEMS

Designed By Russell Storey of Stones Sound Studio.
Welcome to our new range of speaker systems available in economical kit form. Every aspect of the cabinet design has been customized to suit the Peerless drivers specifically with port and box volume tailored to maximize the performance of the HDS and XLS range of premium drivers.

A new improved tweeter has been developed in conjunction Peerless Denmark and Russell Storey, our audio consultant, to closely match the HDS series of mid-woofers. Cabinet development has been achieved using the latest in computer analysis software including LEAP and LMS along with the design experience of Stones Sound Studio who specialize in premium, exotic, custom speaker design. All cabinets are precision made from medium-density custom wood (MDF) with a choice of veneers and the best in computer controlled cabinet manufacturing processes. The Peerless HDS range of drivers and matching XLS range of subwoofers, offer incredible performance and value for money. When correctly developed with our custom designed cabinets, precision crossover matching and premium quality components, the result is a finished speaker that rivals the best musical audio available in the world, and also giving fantastic dynamics and realism to the new digital DVD home theater of today. Thank you and enjoy.

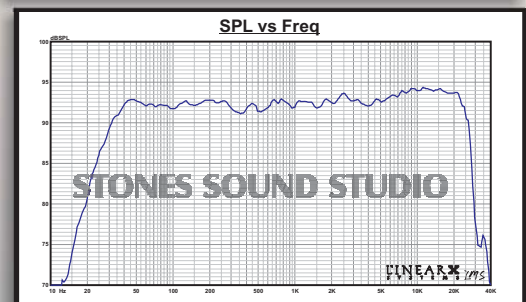
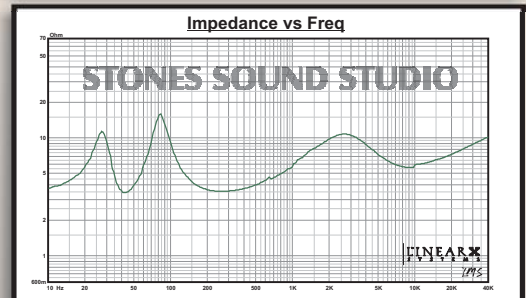
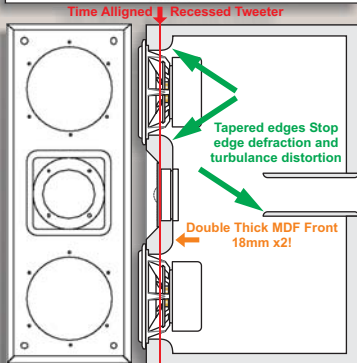

**AUSTRALIAN
DISTRIBUTOR**

WES COMPONENTS

Aust
Asia



enquiries@wescomponents.com

Phone (02)9797-9866 Fax1 (02)9716-6015 Fax2 (02)9799-7051

HDS

High Definition Series

Peerless HDS250 2-Way Time-Aligned Speaker System SSS Rev-4 MK1

Designed By Russell Storey



Contents of KIT250 (Complete Kit):

HDS250-xx	Cabinet (<i>xx=Colour Code</i>) With Speaker Grill
XOK250	Crossover Kit 2-Way
Woofers 5"2x 850528	Peerless Shielded
Tweeter 1" 810653	Peerless Shielded
Screws x20	STS7B (7mmx20mm)
Gasket Tape	GT200 (2m)
Felt cotton waste	(Supplied with box)

HDS250 Instruction Sheet



Tools You Require:

Screwdriver Philips 1 point.
Power Drill (*Battery drill with Torque setting recommended*)
Drill bits (2mm for pilot holes)
Centre punch and/or pen
Hammer and Ruler

Before You Start:

Check the contents of the kit and that all is supplied and in good condition.

Make sure you have a clean work area. It is recommended you use a drop sheet of some kind so that your work does not scratch the cabinet.



CONNECTION TO YOUR AMPLIFIER

WHY A DUAL PAIR TERMINAL CUP ?

Our premium grade HDS Series of speaker systems come with dual pair terminal cups. This facilitates connection to both the upper and lower frequency drivers separately. Generally this is not required for a normal audio system set up but is given as an option for Audiophiles who wish to take advantage of the improvements from Bi-Wiring or Bi-Amping.



BI-WIRE CONNECTION

This refers to the running of separate cables from the amplifier to both the high range and low range drivers. This arguably improves definition and focus by improving the amplifiers damping and reducing intermodulation crosstalk between the woofer and the tweeter.

"An inexpensive tweak for getting the best sound quality from your investment".

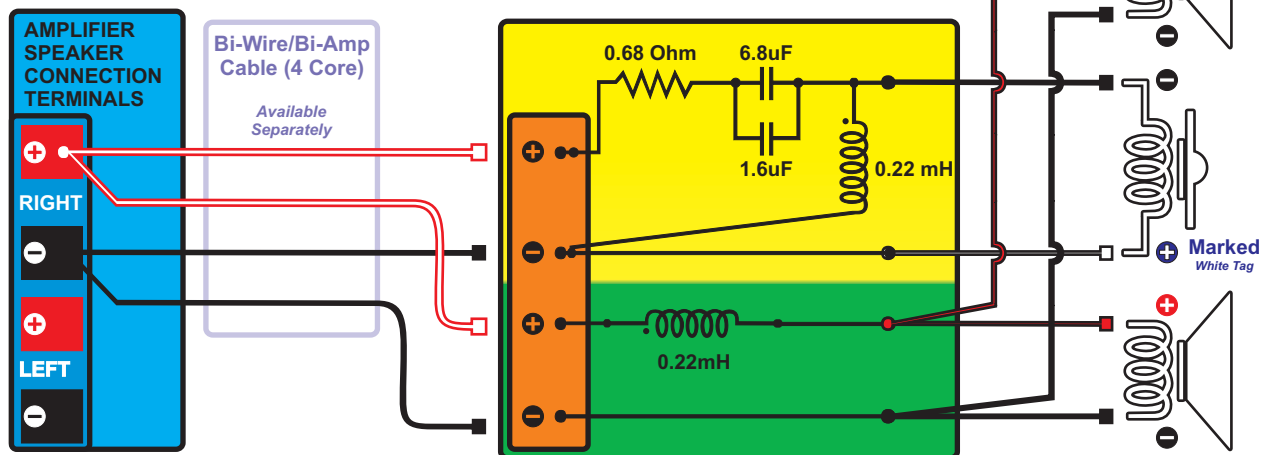

NORMAL SINGLE WIRE CONNECTION

A) If you do not wish to use Bi-Wire or Bi-Amping, then simply leave the supplied "Shorting-Straps" in place on the rear terminal block and use a standard speaker wire pair to connect your speakers to your amplifier system. Please note that the Gold plated terminals must be tightened securely so the straps don't accidentally slip loose over time with the speakers vibration and one driver stops functioning due to being disconnected.

B) As an option to stop this from happening, you could solder in the shorting links on the Crossover Circuit Board (Shown as "Links 1" & 2).

C) Alternatively you could connect the input speaker cable from your system to both terminals.

DOUBLE CHECK ALL WIRING AND PAY PARTICULAR ATTENTION TO POLARITIES AS

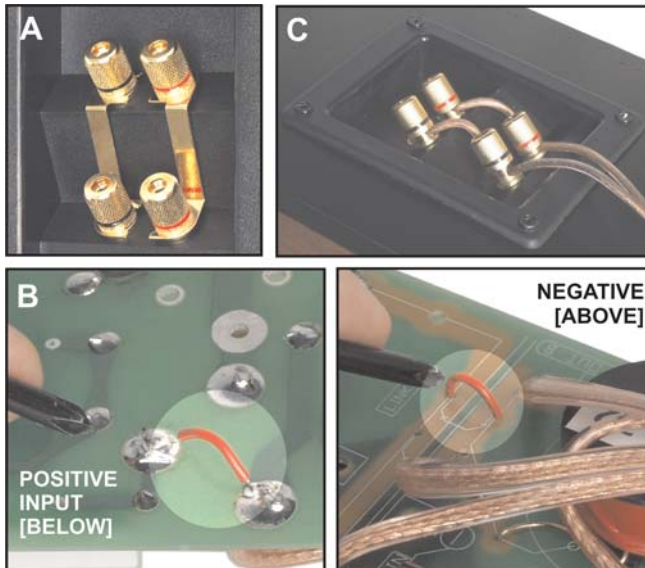

XON250 TO SUIT SPEAKER KIT HDS250

Bessel - Butterworth 2 Way Crossover
Acoustically time aligned with cabinet
Matched to Peerless drivers;

Tweeter	810653
Woofers (X2)	850528
Crossover Frequency	2758Hz
Low Pass Filter	6dB/Octave
High Pass Filter	12dB/Octave

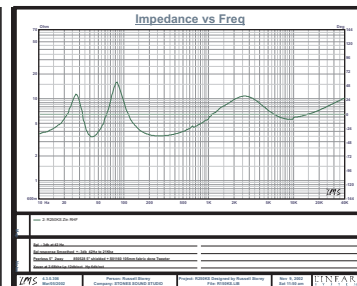
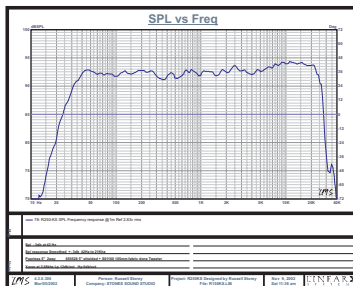

HDS250 - Speaker Box Instruction Sheet

Locate all parts and check condition of each item.
Familiarise yourself with the instructions and parts.
Review how it all fits together before commencing.
Double check your work before final assembly.
Check all connection polarities (*Most common error*).
Insert Crossover 1st, hang the leads out each hole.
Attach connectors and screw in the rear terminal cup.
Position the cables away from the Woofer and port.
Attach connectors and screw in each of the drivers.
Attach speaker cables to amplifier and enjoy!



Please double check your work for best results will achieve best sound.

CROSSOVER CONNECTION:

Ensure all connections are tight and secure with all polarities correct.

If you have a Soldering Iron, a drop of solder makes for excellent reliability.

Velcro strips are supplied as a quick and easy solution for affixing the Crossover Circuit Board directly to the inside bottom of the speaker box. Attach the Velcro strips to the underside of the Crossover Circuit Board. We suggest positioning flat onto PCB where there is no solder blobs to distort the tape and its adhesive surface. Use all six for a most secure fit.

Ensure Bottom Inside of the Box is clean of dust, etc. (with a damp cloth).

Familiarise yourself with the boards connections and where they should go.

Identify the leads to be connected to the rear plate from the diagram below.

Remove Velcro tape to expose the sticky and Insert the Board into the speaker through the woofers hole and stick down on the bottom side.

Now attach the four appropriate leads to the rear terminal plate.

Insert the rear terminal plate into the cabinet with the supplied screws. Take care not to over tighten and crack the plastic.

Next stage is to install the drivers.....

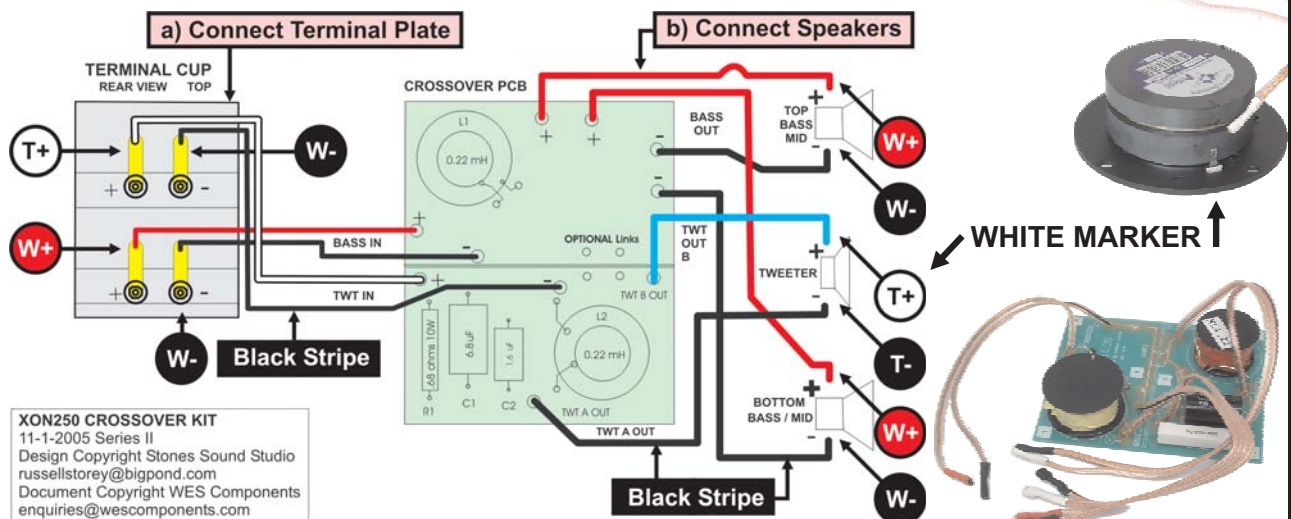

HDS250 - Speaker Box Instruction Sheet



Place your speaker cabinet on a non-slip, non-scratch surface.

Insert the speaker jack panel into the cabinet. Internal speaker cables thread thru the Internal Damping Cloth. Aim the 4mm Banana plugs UP (*This stops the plugs falling out!*). Screw in using four of the supplied black screws, not too tight or you may damage the plastic panel.

Check the cables have sufficient length to reach each speaker and don't catch anywhere, or block the port.

Apply the gasket tape. This is essential for an air-tight seal. Use the speaker drivers packaging to hold and protect the face and dome/surround when applying the gasket tape.. For the tweeter, carefully run the tape around the outer circumference once then cut off excess.

For the woofer, keep to the inner rim of the drivers mounting flange, again, only once around then cut.



Drilling pilot holes for the woofer:

Drop in the driver and align it to the side edge of the cabinet



making sure it is absolutely square.

Hammer in centre punch for the six screw holes.

Remove the driver and drill a 2mm pilot hole for each screw.

If the felt is supplied separately, insert it now. The speaker box designer recommends a modest amount on the rear panel only.

This gives the best sound and response.

Ensure the felt is secured and will not touch any moving part of the woofers or obstruct the port tube on the back panel.

Affix using heat glue or a small staple gun.

Check the run of the speaker cables for ample reach and that they too will not touch the woofer nor obstruct the port or rattle against the cabinet walls, etc.



Attach the drivers.

Apply the spade connectors to their respective drivers, ensuring you have the correct polarity. We recommend you also solder these connections for excellent long-term reliability. **BEWARE**

not to apply too much heat to the tweeter contacts or damage to the plastic mounts can occur. Only a small amount of solder is required for a secure connection.

Screw in the drivers, carefully, moving to opposing screws and tightening until the driver is flush with the cabinet and not too tight as to thread the screw. If using an electronic screwdriver, set it to a medium torque setting, and use your hand for the final tightening.



HDS250 Positioning and usage:

The HDS250 speaker system has been developed for premium home theatre and music reproduction. The highly efficient dual 5" drivers will fill a reasonable sized room with ample volume from any sized amplifier, from 10 to 110 Watts. Speaker stands or a shelf of 600mm in height is best, however as a general rule the tweeters should be about ear height. Do not obstruct the rear port, about 10/15cm clearance minimum. The HDS250s' are fully shielded so they can be positioned as close to the TV as you like, but around 10/15cm out is best for Dolby[®]. For optimum music listening it is desirable to have the speakers approximately 2.8M apart, around 3M away from the centre listening positioned and toed-in by 10° if desired, however, this obviously changes depending on the room acoustics and aesthetic or domestic compromises.



Stones Sound Studio

AUDIOPHILE MONITOR 2-WAY 3-SPEAKER SATELLITE & SURROUND SPEAKER

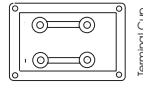
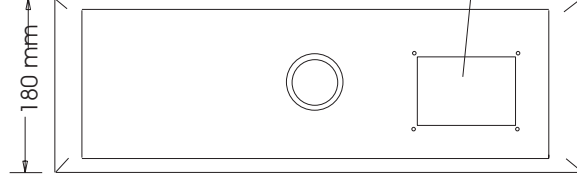
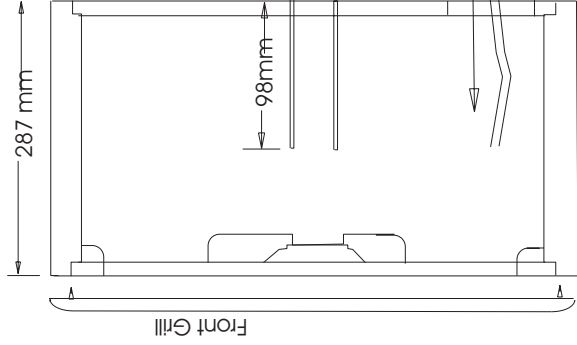
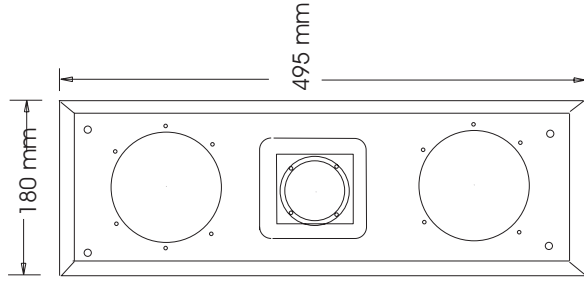
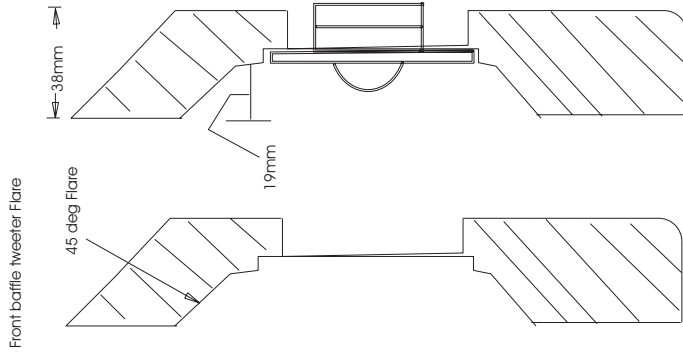

Construction Notes

- Cabinet Thickness varies with thickness of chosen material
- Internal Dimensions W x D x H mm (146 x 263 x 493)
- Top /bottom / Left/Right side panels mitre joints
- Front and rear baffles rebated in 17mm
- Front Twin Baffles rebated in 34mm
- Outside Dimension = Inside Dim + 17mm raw MDF
- Peerless 5" Hole Cut out = 120 mm
- Vent ID = 50 mm
- Vent length = 146mm

ITEM PART NUMBER NO. / NZBMS	General Dimensions Diagram	MATERIAL SPECS:	QTY.
2x Peerless 5" Shielded Bass-Mid Drivers 655228 2x Peerless 1" Shielded Fabric Tweeter Drivers 655229	WES Components Dual Terminal Cup Code JZ81 - BxHxDr: 26x34x17mm		
UNLESS OTHERWISE SPECIFIED DIMENSIONS ARE IN MILLIMETRES TOLERANCES ARE ± 0.5 mm			
DO NOT MANUALLY UPDATE.		APPROVALS	DATE
		DRAWN Russell Storey	13-01-2002
		CHECKED Jim Ryan	10-09-2003
MATERIALS: MDF 12mm Particle Board MDF 18mm Particle Board FIBRE Veneer of Wood Veneer			
NEXT ASSY:	USED ON:	SIZE (DIM. NO.)	REV.
Audiophile Satellite, Surround, Mains	Audiophile Type MTM Coastal Design Counter-Speak Tweeter Flare System	AS	Loop 0003
APPLICATION		SCALE: XXXX	CAD FILE: HDS250_INS.dwg
AUDIOPHILE KIT SPEAKER		SHEET 1 of 1	
HDS250			