

danish sound technology



enter a world of speakers.....

www.d-s-t.com.au

PEERLESS SUBWOOFER - RESOLUTION SERIES



RESOLUTION SERIES

extra high power performance subwoofer

Design emphasis on the Resolution series subwoofer has been to develop a strong, indestructible high performance driver that handles massive power, yet is light in weight and suitable for compact enclosures and vehicles. This unique series is highly efficient and has a long stroke design for smooth low frequencies at high volumes without cone breakup or other distortions.

SUBWOOFER DETAILS:

Strong and Light Weight Aluminum Die Cast Basket
 Reinforced Paper Pulp Cone To Reproduce Rigid Bass
 Long Stroke For Better Dynamics At Higher Volumes
 Gold Plated Terminals. Tapered Pole Piece Vent.
 Optimized Parameters For Small Box Dimensions
 Superior Power Handling For High Performance SPL



Model	R10	R12	R15
Size	10 Inch	12 Inch	15 Inch
Rec. Amp Power	30-400W	30-400W	30-1000W
Impedance	4 Ohm	4 Ohm	4 Ohm
Imp. DC	3.5 Ohm	3.5 Ohm	3.2 Ohm
Fs	30 Hz	25 Hz	22.3 Hz
Qts	0.33	0.33	0.34
Vas	40.6	99.7	183.9
Sensitivity (2.83V/1M)	90dB	91.5dB	92.3dB
Voice Coil Diam.	50	50	65
Examples: Box Volume / Box Tuning			
Sealed	14L/58Hz	17L/65Hz	35L/65Hz
Vented	15L/36Hz	28L/28Hz	60L/24Hz
Band Pass	10+8L/68Hz	24+19L/68Hz	49+39L/48Hz

danish sound technology



enter a world of speakers.....

www.d-s-t.com.au

PEERLESS COMPONENT SYSTEMS - RESOLUTION SERIES



RESOLUTION SERIES

designed for outstanding sound quality and high SPL power handling

Using advanced speaker design techniques and premium quality materials, Peerless have produced an excellent two-way component driver system that achieves a detailed natural sound for your vehicle. Durable polymer cone with high exertion surround and low compression open ventilated voice coil motor achieves phenomenal sound quality at impressively high volume levels.

WOOFER DETAILS:

Strengthened steel basket
Mineral filled polymer cone
Low compression design
Ventilated aluminum voice coil
Long exertion NBR rubber surround
Long life materials and high SPL

TWEETER DETAILS:

High Quality 1" Soft Dome tweeter
Flush and Angle mounting options
Multi-component 12dB crossover
Brass terminals. Protection circuit
Selectable 3 position attenuator
Audiophile quality high-end extension

Model	R5	R6
Size	5 Inch	6 Inch
Frequency Res.	55-20Khz +/-3dB	45-20Khz +/-3dB
Sensitivity	91dB at 0.5m 2.83v	91dB at 0.5m 2.83v
Power RMS	90W	100W
Power Peak	180W	200W
Impedance	4 Ohm	4 Ohm
Crossover Slope	12dB per Octave	12dB per Octave
Woofers Mounting Details		
Fitting Hole	117mm	141mm
Mounting Depth	58mm	62mm
Tweeters Mounting Details		
Fitting Hole	43 or 55mm*	43 or 55mm*

* Depending on housing used.

Congratulations on your purchasing a new 'Peerless' Resolution Series car subwoofer!!! Subwoofer installation requires woodwork skill and experience on dis/reassembling car interiors .If you are not sure you have such an experience, please let your local authorized dealer to do it.

Warning: Playing too loud music in automobile can permanently damage your hearing as well as hinder your ability to hear traffic. We recommend that you play low level when driving.

Bass reproduction in your car: Depending on the interior size in your car, bass frequency below 80Hz is boosted by nearly 12dB/oct as the frequency decreases . This effect plays an important role along with free space response on the enclosed datasheet for your subwoofer .

Adjusting amplifier to suit your subwoofer: The subwoofer level can be adjusted to suit the environment ,placement and personal preference. The sound should be an integrated part of your system. Too high bass level will destroy the clarity of the sound.

Choose an Enclosure : Resolution Series subwoofer are optimized to perform the best bass in small sealed or vented ,band pass enclosures. It can still work in finite- baffle mounting. But power handling will be greatly reduced because there is no enclosed volume of air to prevent the cone to pass its excursion limits. For this reason, we don't recommend this way of mounting. First you should choose the type of enclosure based on the music you normally listen to, how much power your amplifier can deliver, how much space you can devote to the subwoofer system inside your vehicle.

Sealed cabinet: Sealed cabinet will give your most controlled and accurate bass than any other type of enclosure, it is well suited for all kinds of music. The required sealed enclosure is always smaller than other type of cabinet. Existing enclosures can easily be found. Sealed cabinets requires more power because of the low sensitivity of the system. So you need to choose an amplifier with more power output. We don't recommend this kind of installation if you want to achieve highest SPL, especially for competition purpose.

Vented cabinet: Vented cabinet will provide better efficiency in 40-50Hz.If you use small amplifier, the vented system will still provide more bass from less power. The vented cabinet also suits for all kinds of music, but the enclosure must be made **exactly** as the specifications like the size of cabinet, port. Normally an optimized vented system is always bigger than sealed system, it will take more space inside car. You can ask 'Peerless' authorized dealer to verify if you want to build the cabinet yourself.

Band pass cabinet: If highest SPL (Sound pressure level) is what you want, choose band pass. On the other hand, you will lose some sonic accuracy for expense. Band

pass enclosure is very critical to the size of cabinet and port. Normally it needs computer aid tool to make the design. If you are an experienced installer and have woodwork skill, you may be interested in making it by yourselves. We don't recommend none-professional people to do this. Normally band pass enclosure requires lots of space in your car.

Specifications/Models	Resolution10	Resolution12	Resolution15
Impedance(Ohm)	4	4	4
DCR(Ohm)	3.5	3.5	3.2
Fs(Hz)	30	25	22.3
Qts	0.33	0.33	0.34
Vas(Litres)	40.6	99.7	183.9
BL(N.A)	14.4	14.8	17.7
Moving Mass(g)	107	139	255
Cms(mm/N)	0.26	0.29	0.2
Sensitivity 2.83V/1m	90	91.5	92.3
Recommended Amplifier Output (W)	30-400	30-400	30-1000
Xmax(mm)	10.2	10.2	11.4
Thickness of top plate(mm)	8	8	8
Diameter of Voice Coil(mm)	50	50	65

Resolution 10 cabinet/response:

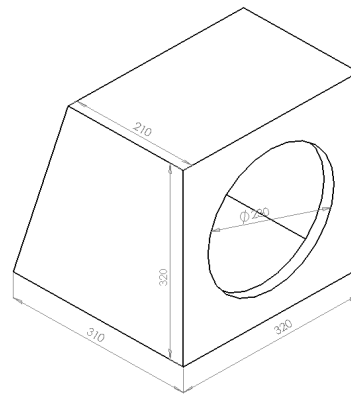
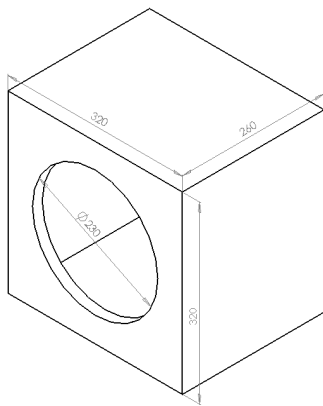

18mm MDF board ,filled with 100% absorptive material.

Sealed box,14 liters in car simulation(dB SPL at 1m) with 300W

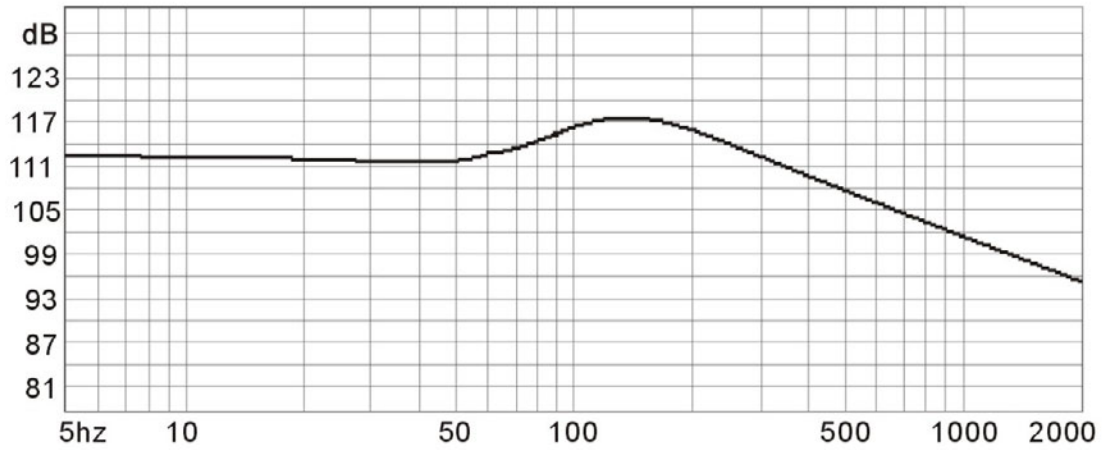

Resolution 12 cabinet/response:

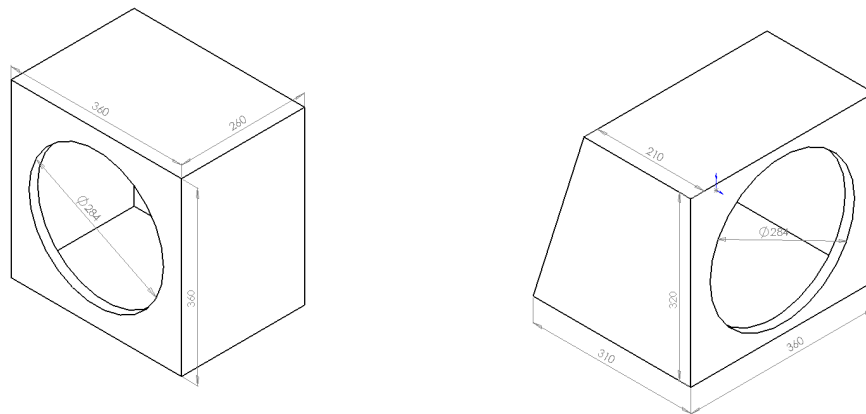

18mm MDF board ,filled with 100% absorptive material.

Sealed box,17 liters in car simulation(dB SPL at 1m) with 300W

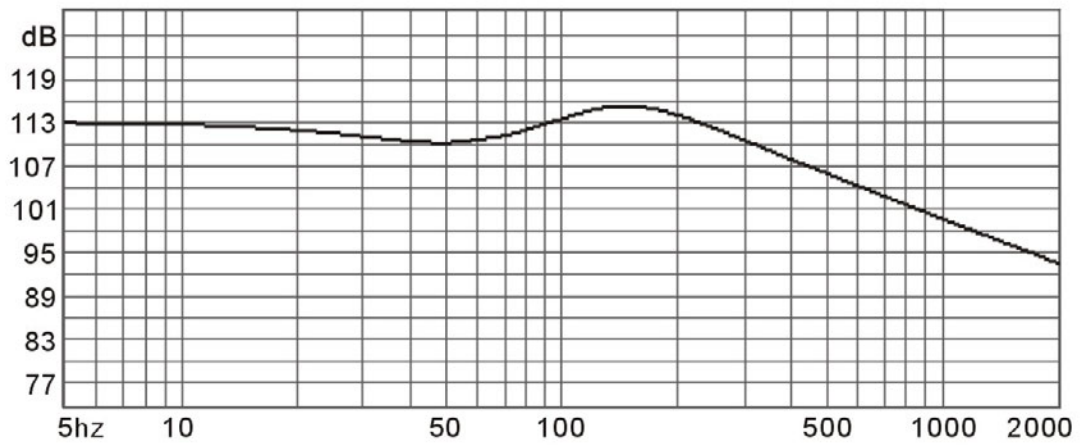

Resolution 15 cabinet/response:

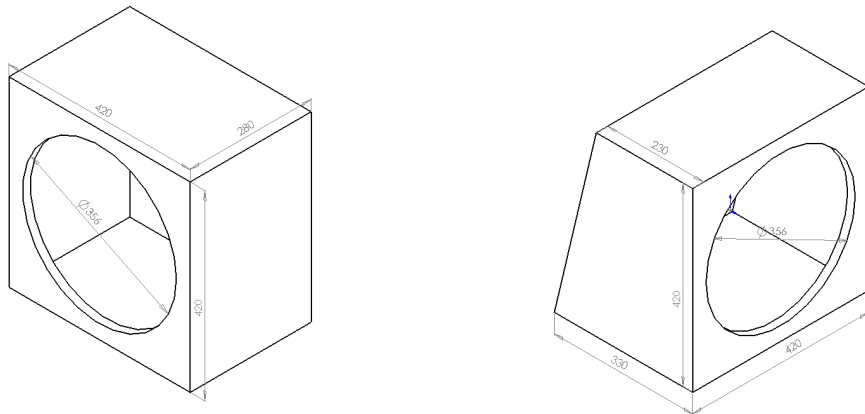

18mm MDF board ,filled with 100% absorptive material.

Sealed box,34 liters in car simulation(dB SPL at 1m) with 300W

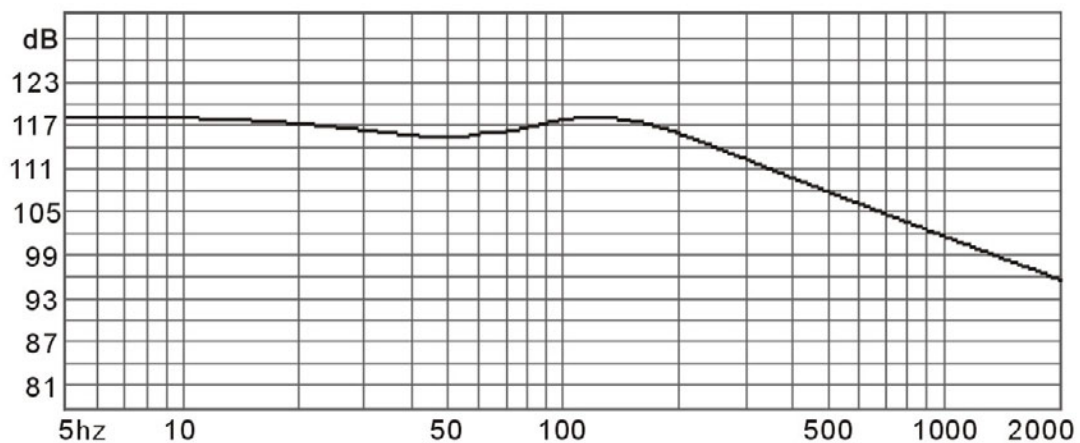

Recommended Enclosure Tuning

Model of unit	Sealed	Vented	Bandpass
R.10	Vabr=14Liters/Bessel Tuning=58Hz	Vabr=15Liters/QB3 Tuning=36Hz	Vabr=10+8 Liters/Butterworth Tuning=68Hz
R.12	Vabr=17Liters/EQ Tuning=65Hz	Vabr=28Liters/Bessel Tuning=28Hz	Vabr=24+19 Liters/Butterworth Tuning=57Hz
R.15	Vabr=35Liters/Butterworth Tuning=65Hz	Vabr=60Liters/Bessel Tuning=24Hz	Vabr=49+39 Liters/Butterworth Tuning=48Hz

10" Automotive



Type Number: 822007

Features:



Specs:

Electrical Data

Nominal impedance	Zn	4	ohm
Minimum impedance	Zmin	4.5	ohm
Maximum impedance	Zo	71.6	ohm
DC resistance	Re	3.5	ohm
Voice coil inductance	Le	4.5	mH
Capacitor in series with x ohm	Cc	--	uF

T-S Parameters

Resonance Frequency	fs	35.1	Hz
Mechanical Q factor	Qms	8.47	
Electrical Q factor	Qes	0.43	
Total Q factor	Qts	0.41	
Ratio fs/Qts	F	85	
Force factor	Bl	15.3	Tm
Mechanical resistance	Rms	3.42	Kg/s
Moving mass	Mms	131.3	g
Suspension compliance	Cms	0.16	mm/N
Effective cone diameter	D	21.2	cm
Effective piston area	Sd	352	cm ²
Equivalent volume	Vas	26.8	ltrs
Sensitivity		88	dB
Ratio BL/√(Re)		--	

Power handling

100h RMS noise test (IEC)	--	W
Long-term Max System Power (IEC)	--	W
Max linear SPL (rms) @ power	--	dB/W
Short Term Max power	--	W

Voice Coil and Magnet Parameters

Voice coil diameter	51	mm
Voice coil height	--	mm
Voice coil layers	--	
Height of the gap	--	mm
Linear excursion +/-	--	mm
Max mech. excursion +/-	--	mm
Flux density of gap	--	mWb
Total useful flux	--	mWb
Diameter of magnet	--	mm
Height of magnet	--	mm
Weight of magnet	--	Kg

Frequency:

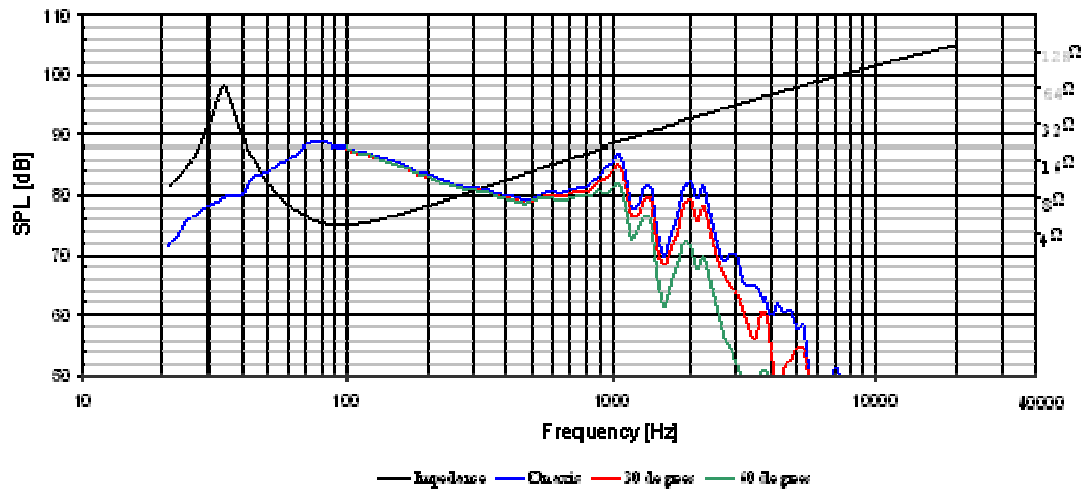

Mechanical Dimensions:

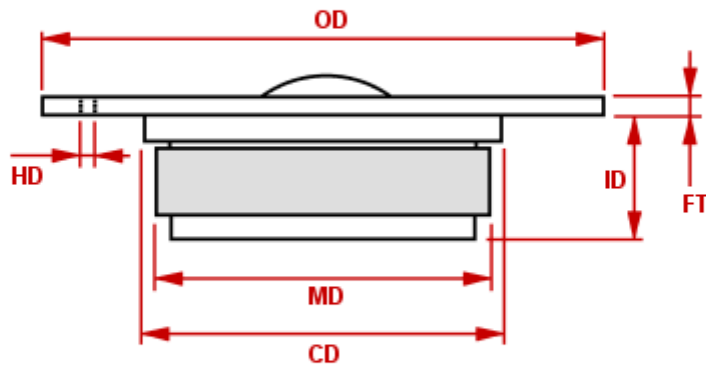

12" Automotive



Type Number: 822008

Features:



Specs:

Electrical Data

Nominal impedance	Zn	4	ohm
Minimum impedance	Zmin	4.5	ohm
Maximum impedance	Zo	67.8	ohm
DC resistance	Re	3.5	ohm
Voice coil inductance	Le	5.3	mH
Capacitor in series with x ohm	Cc	--	uF

T-S Parameters

Resonance Frequency	fs	30	Hz
Mechanical Q factor	Qms	8.24	
Electrical Q factor	Qes	0.45	
Total Q factor	Qts	0.43	
Force factor	Bl	15.6	Tm
Mechanical resistance	Rms	3.81	Kg/s
Moving mass	Mms	166.5	g
Suspension compliance	Cms	0.17	mm/N
Effective cone diameter	D	24.4	cm
Effective piston area	Sd	466	cm ²
Equivalent volume	Vas	50.7	ltrs
Sensitivity (2.83V/1m)		89.7	dB
Ratio BL/√(Re)		--	
Ratio fs/Qts	F	70	

Power handling

100h RMS noise test (IEC)	--	W
Long-term Max Power (IEC 18.3)	--	W
Max linear SPL (rms) @ power	--	dB/W
Short Term Max power (IEC 18.2)	--	W

Voice Coil and Magnet Parameters

Voice coil diameter	51	mm
Voice coil height	--	mm
Voice coil layers	--	
Height of the gap	--	mm
Linear excursion +/-	--	mm
Max mech. excursion +/-	--	mm
Flux density of gap	--	mWb
Total useful flux	--	mWb
Diameter of magnet	--	mm
Height of magnet	--	mm
Weight of magnet	--	Kg

Notes:
IEC specs refer to IEC 60268-5 third edition.
All Tymphany products are RoHS compliant.

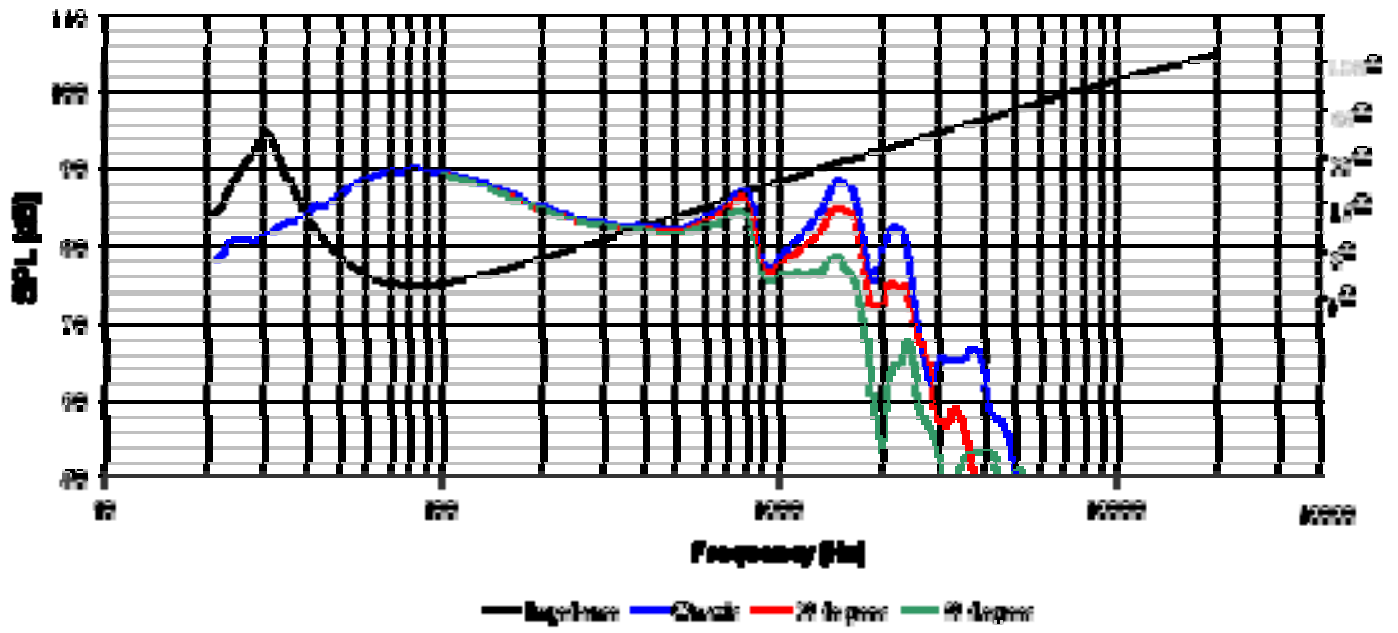

15" Automotive



Type Number: 822009

Features:



Specs:

Electrical Data

Nominal impedance	Zn	4	ohm
Minimum impedance	Zmin	4.2	ohm
Maximum impedance	Zo	51.2	ohm
DC resistance	Re	3.2	ohm
Voice coil inductance	Le	5.7	mH
Capacitor in series with x ohm	Cc	--	uF

T-S Parameters

Resonance Frequency	fs	29.1	Hz
Mechanical Q factor	Qms	7.72	
Electrical Q factor	Qes	0.51	
Total Q factor	Qts	0.48	
Ratio fs/Qts	F	70	
Force factor	Bl	18.7	Tm
Mechanical resistance	Rms	7.28	Kg/s
Moving mass	Mms	307	g
Suspension compliance	Cms	0.1	mm/N
Effective cone diameter	D	33.7	cm
Effective piston area	Sd	892	cm ²
Equivalent volume	Vas	106.9	ltrs
Sensitivity		91.1	dB
Ratio BL/√(Re)		--	

Power handling

100h RMS noise test (IEC)	--	W
Long-term Max System Power (IEC)	--	W
Max linear SPL (rms) @ power	--	dB/W
Short Term Max power	--	W

Voice Coil and Magnet Parameters

Voice coil diameter	51	mm
Voice coil height	--	mm
Voice coil layers	--	
Height of the gap	--	mm
Linear excursion +/-	--	mm
Max mech. excursion +/-	--	mm
Flux density of gap	--	mWb
Total useful flux	--	mWb
Diameter of magnet	--	mm
Height of magnet	--	mm
Weight of magnet	--	Kg

Frequency:

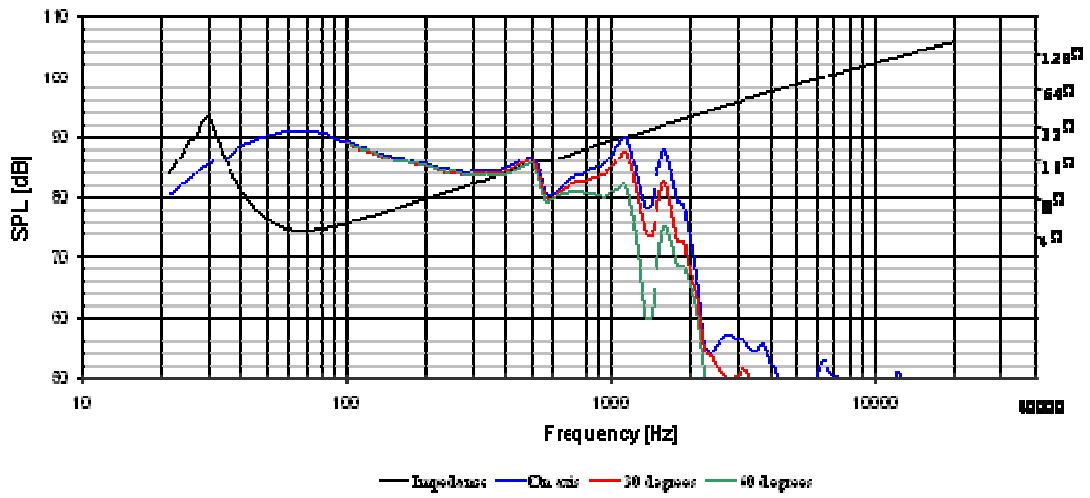

Mechanical Dimensions:

