

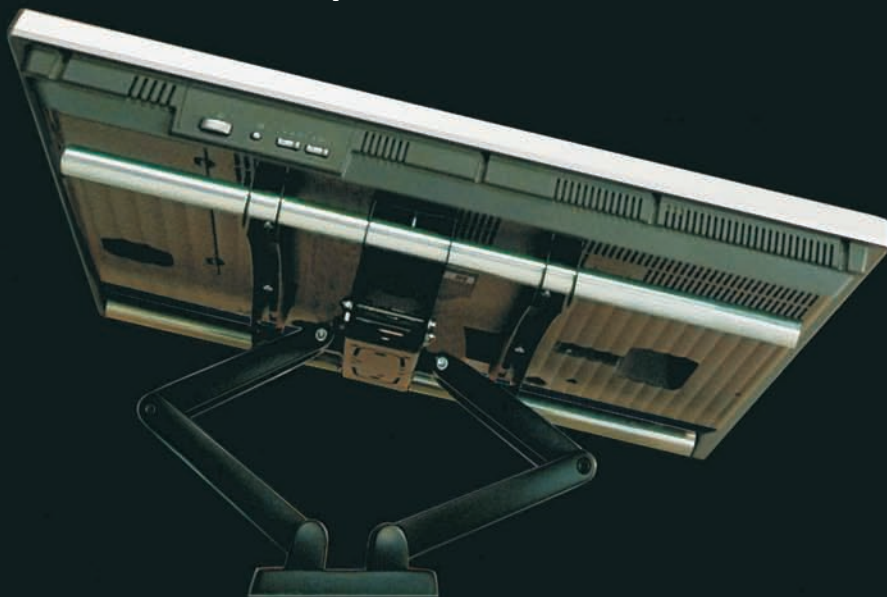

OMB AUDIO VIDEO SUPPORTS. ITALIAN DESIGN IN MOTION.
2011 CATALOGUE.



**omb**[®]

AUDIO VIDEO SUPPORTS

creating space beautifully.



Sponsor of the
World Superbike
Championship team
B & G Racing
Ducati



Innovation and tradition

Abbiamo da sempre l'obiettivo di rendere facile la vita dei nostri clienti. Utilizziamo le ultime scoperte tecnologiche per soddisfare le esigenze di chi vuole sempre avere il massimo della sensazione visiva e uditiva. Da una tradizione nata in Trentino negli anni Sessanta abbiamo sviluppato supporti di alto profilo tecnologico e dalla linea originale per ogni tipo di uso e apparecchio video e audio. Una vasta gamma di prodotti per tutte le esigenze e per tutti i gusti.

Facile vivere emozioni.

OMB è un'azienda italiana leader nel settore dei supporti per Tv con quarant'anni di esperienza.

Assicuriamo competenza e conoscenza.

Forniamo ai nostri clienti risposte concrete e corrette in piena sintonia con le esigenze e i sogni dei consumatori.

The O.M.B.'s objective has always been to improve the quality of people's lives through the latest technologies, together with the goal to satisfy the needs of those who want to experience the best visual and auditory sensations.

It's easy to live an emotion.

The company, situated in the Trentino region, Italy, was created in the sixties OMB now manufactures superior technologic supports with an original design suitable for every type of video and auditory appliance: a range of products able to meet the expectations of the most demanding customers and the most refined tastes. OMB is a leading provider of Tv supports and boasts 40 years of experience: a guarantee of expertise and knowledge. It strives to be honest and attuned to the needs and dreams of its customers.





omb[®]

Model :

06128

OMB1G0-01B

LEDFIX

Art :

MAX vesa

Gross Weight :

6,5 kgs

PCS/CTN :

12

COLOR :

BLACK

MEAS :

55 x 25 x 25

www.ombus.it
MADE IN ITALY
20/05/2010

OMB fabbrica da sempre supporti tecnologicamente perfetti e all'avanguardia. Ma, soprattutto, fabbrica supporti esteticamente belli. Sono infatti apprezzati per il loro inconfondibile design "Made in Italy" che ha reso famosi in tutto il mondo i prodotti italiani. Ecco i nostri obiettivi: fornire accessori esteticamente perfetti e contemporanei per poter essere collocati armoniosamente anche dentro gli interni più sofisticati. Il tutto in un seducente rapporto qualità-prezzo.

L'azienda italiana, leader nel settore dei supporti per Tv

The leading Italian company for Tv supports

OMB manufactures perfect supports using state-of-the-art technologies. Design and aesthetics are also a very important part of the OMB's philosophy and all its products can boast the unique "Made in Italy" quality. OMB aims to manufacture high-quality, modern, aesthetic products which can fit harmoniously in any ambient, even the most sophisticated.

All this in an enticing quality-price ratio.

Totale rispetto per l'ambiente

OMB lavora, fin dalla sua fondazione, con un rispetto particolare dell'ambiente. Il nostro impegno è concretamente finalizzato a promuovere la sostenibilità ambientale, migliorando i processi di produzione, pianificando la raccolta differenziata dei materiali di scarto, utilizzando imballaggi riciclabili. Inoltre, da quest'anno, a questo processo virtuoso si aggiunge anche l'installazione, presso la nostra sede, di pannelli solari per la produzione di energia elettrica tramite conversione fotovoltaica. Quest'anno intendiamo produrre 99.000 kWh di energia, garantendo così la pressoché totale autonomia della nostra attività con energia pulita.



Totale respect for the environment

The protection of the environment is an important part of OMB's business philosophy. It is committed to: promote sustainable production, environmentally friendly technologies and products; organize selective collection of waste; use recyclable packaging and develop alternative sources of energy like solar energy with photovoltaic conversion. This year OMB will be able to produce 99.000 kWh of energy which means that it will function nearly entirely on solar energy.





Fisso
Fixed



1
Con 1 snodo
With 1 articulation

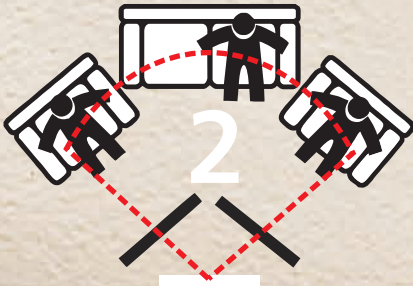

2
Con 2 snodi
With 2 articulations

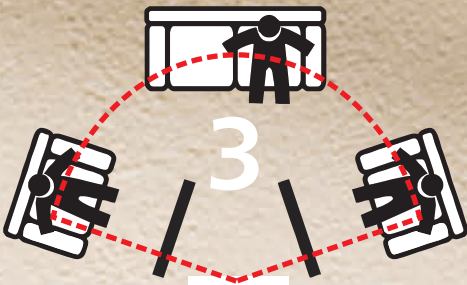

3
Con 3 snodi
With 3 articulations



Sempre al centro dell'azione
Always at the centre of the action

creating space beautifully



Per gustare le emozioni della vita è necessario essere sempre nel punto giusto. I supporti OMB seguono i tuoi movimenti per farti sentire sempre al centro della scena. **Facile vivere emozioni.**

To be able to enjoy all of the emotions that life offers you, it's necessary to be in the right place at the right time. OMB's Tv supports follow your movements and make you feel the centre of attraction, always. **It's easy to live an emotion.**

Italian design in motion

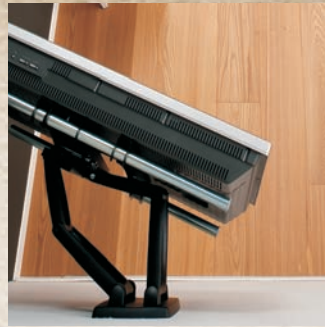
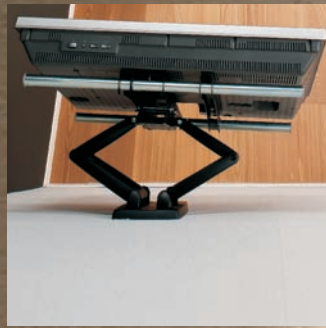
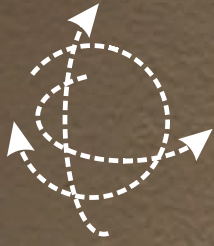

Leggenda / Key

MISURA MASSIMA TV LCD / LED / PLASMA (VEDI P. 12 - 13)
 MAXIMUM SIZE LCD / LED / PLASMA TV (SEE P. 12 - 13)

NUMERO DI ARTICOLAZIONI
 NUMBER OF ARTICULATIONS

3



MAX. DIMENSIONE TV
 MAX. TV DIMENSION



PORTATA
 WEIGHT CAPACITY



DISTANZA MINIMA DAL MURO
 MINIMUM DISTANCE FROM WALL



DI FACILE INCLINAZIONE
 EASY TILT



CAVI NASCOSTI
 HIDDEN CABLE



SISTEMA DI FACILE AGGANCIAMENTO
 EASY HANGING SYSTEM



CLICK FIX SYSTEM



DISTANZIATORE
 SPACER



ADATTAMENTO UNIVERSALE
 TO FIT ALL SIZES



LIVELLA INCLUSA
 LEVEL INCLUDED



CINGHIA DI SICUREZZA
 SAFETY BELT



TELECOMANDO
 REMOTE CONTROL



FILMATO PRODOTTO,
 PRODUCT VIDEO*

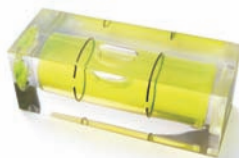
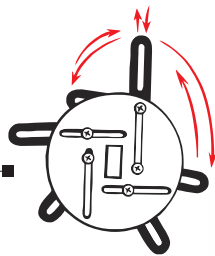
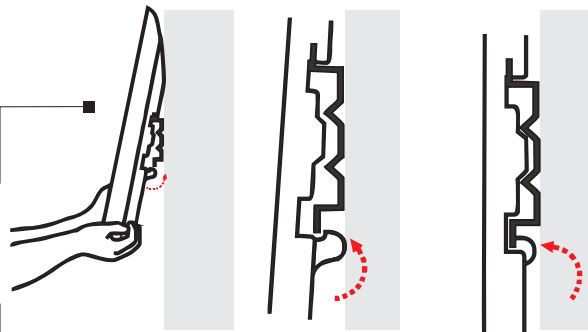
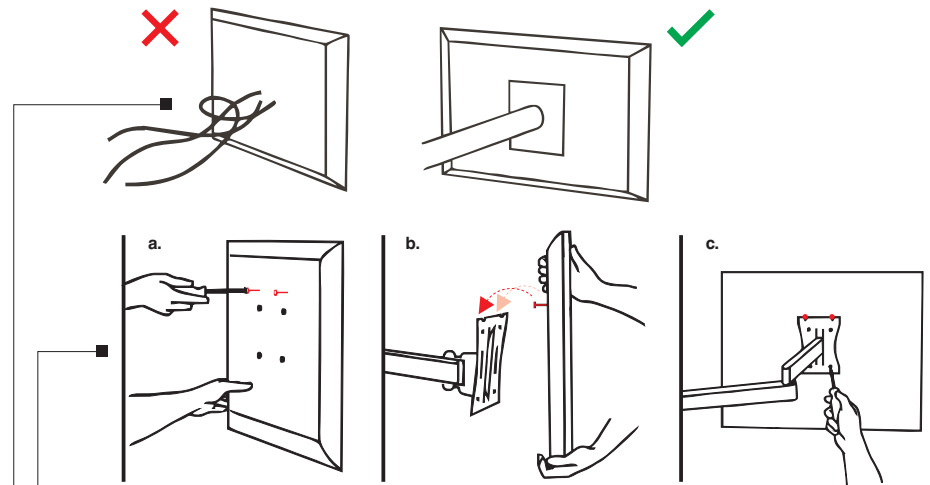

*www.ombitaly.it

omb® Quick search

Le pagine dove puoi trovare supporti per TV al plasma LED e LCD fino a...
The pages where you can find supports for plasma, LED and LCD TVs up to...

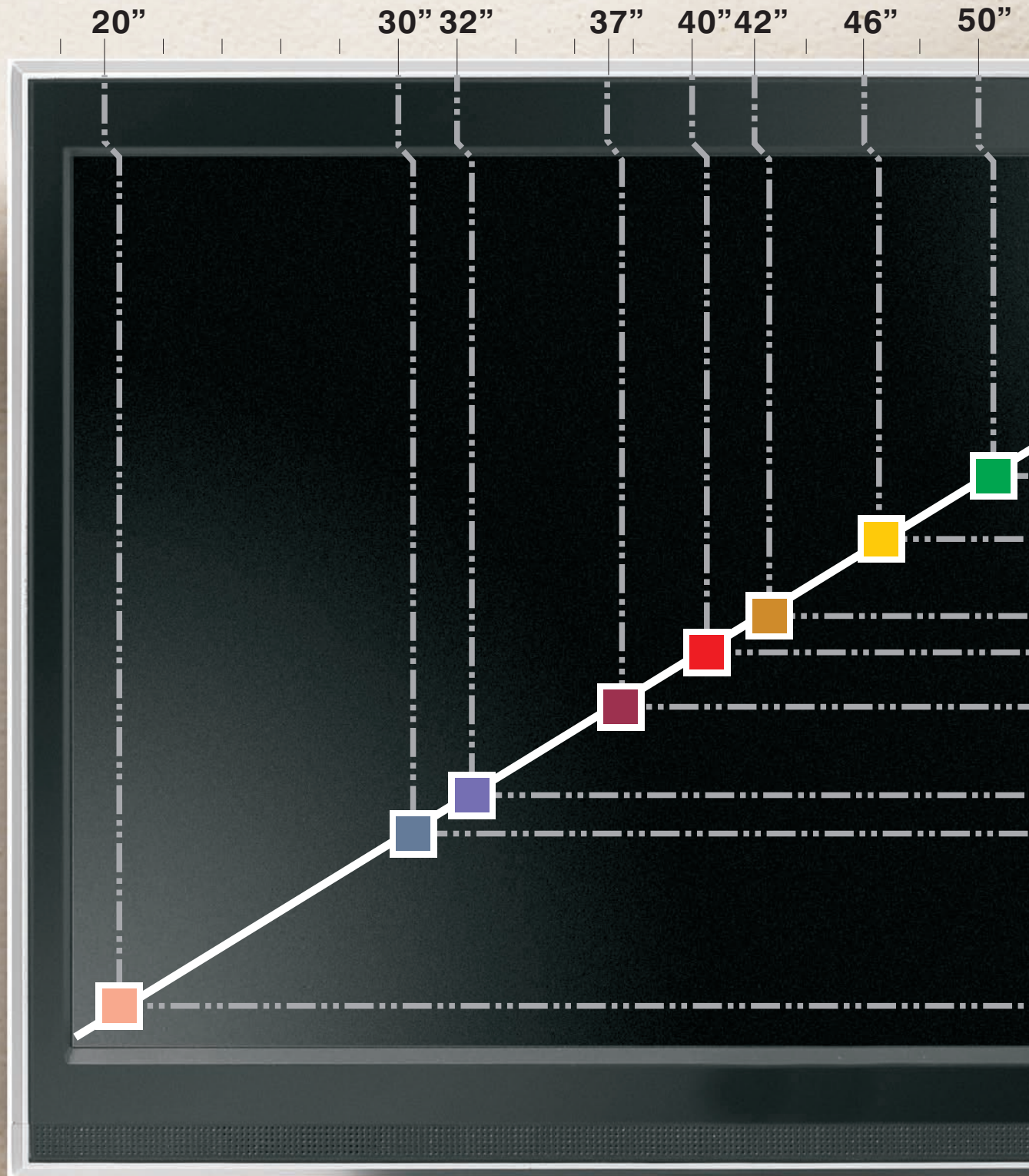

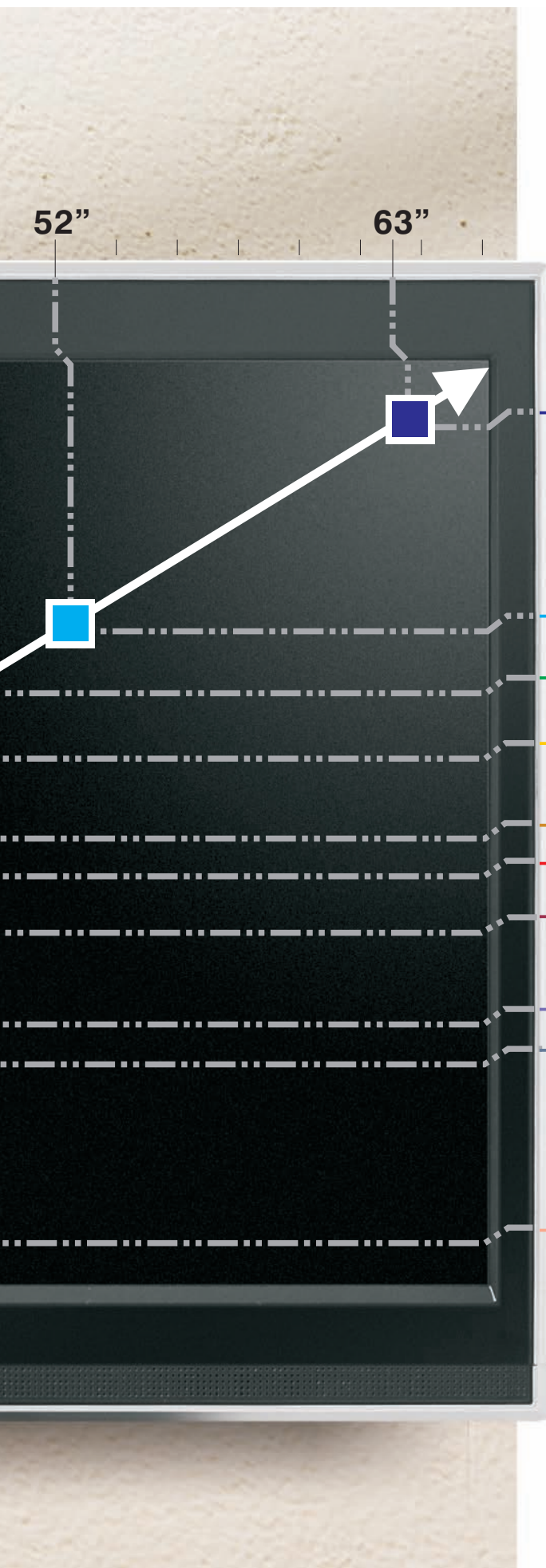

MODEL	COD.	PG.
REACH STOP	06123	40
REACH GO	06124	41
QUICK LEVEL	06127	22
SLIM 800	06139	25
SLIM TILT 800	06129	26
EASY THREE 800	06149	46

MODEL	COD.	PG.
SLIM 600	06144	25
SLIM TILT 600	06145	26

MODEL	COD.	PG.
O-4	06137	32
LUNAR REACH	06093 - 26093	38
EASY BIG	06066 - 26066	43
NEW MAGELLANO	06104	49

MODEL	COD.	PG.
LED FIX	06128	23

MODEL	COD.	PG.
REMOTE SWING	06151	19
REMOTE TILT	06150	18

MODEL	COD.	PG.
EASY THREE 400	06118	46
EASY GO 200	06143	42
DECODER BOX	06120	51

MODEL	COD.	PG.
O-1	06131	30
O-2	06133	30
O-3	06135	31
LUNAR 1	06105 - 26105	36
LUNAR 2	06107 - 26107	37
LUNAR 3	06108 - 26108	36
LUNAR GENIO	06106	39
SLIM 2	06147	24
SLIM 3	06148	24
EASY FOUR	06079 - 26079	43

MODEL	COD.	PG.
O-1	06130	30
O-2	06132	30
O-3	06134	31
LUNAR 1	06094 - 26094	36
LUNAR 2	06091 - 26091	37
LUNAR 3	06092 - 26092	36
SLIM 200	06154	27
EASY GO 100	06142	42
EASY TWO EXTRA	06115 - 26115	44
EASY THREE EXTRA	06117 - 26117	45

MODEL	COD.	PG.
HI-SOLUTION	06073 - 26073	47
MONOSOLUTION	06070 - 26070	47
BI-SOLUTION	06071 - 26071	48
TRI-SOLUTION	36072 - 26072	48
EASY SMALL	06076	43
EASY TWO	06077 - 26077	44
EASY THREE	06078 - 26078	45

MODEL	COD.	PG.
OYSTER	26075	50

I nostri prodotti / Our products

p.16

Electric supports

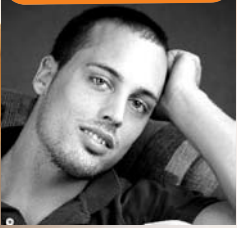

p.34

More LED, LCD Plasma supports



p.28

The ultimate design



p.20

New LED, LCD Plasma supports

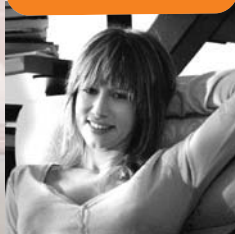

p.60

Audio supports

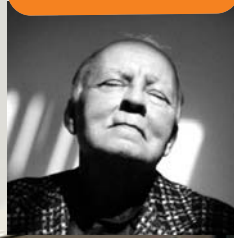

p.56

Classic TV supports



p.52

Projector supports

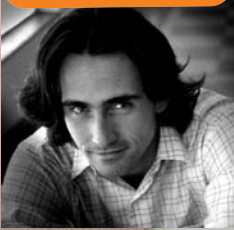

p.62

Surfaces



“

Nella mia nuova casa volevo un arredamento elegante ed essenziale. Ma non sapevo dove collocare la televisione. Volevo che ci fosse, ma che non si vedesse quando non è utilizzato. Quando ho scoperto i supporti telecomandati della OMB la mia casa è stata finalmente completa

In my new home I wanted elegant, essential furnishings. I didn't know where to put the TV because I didn't want it to be seen when it wasn't in use. When I discovered OMB's remote control supports, my home was finally complete

”

Marco, 30

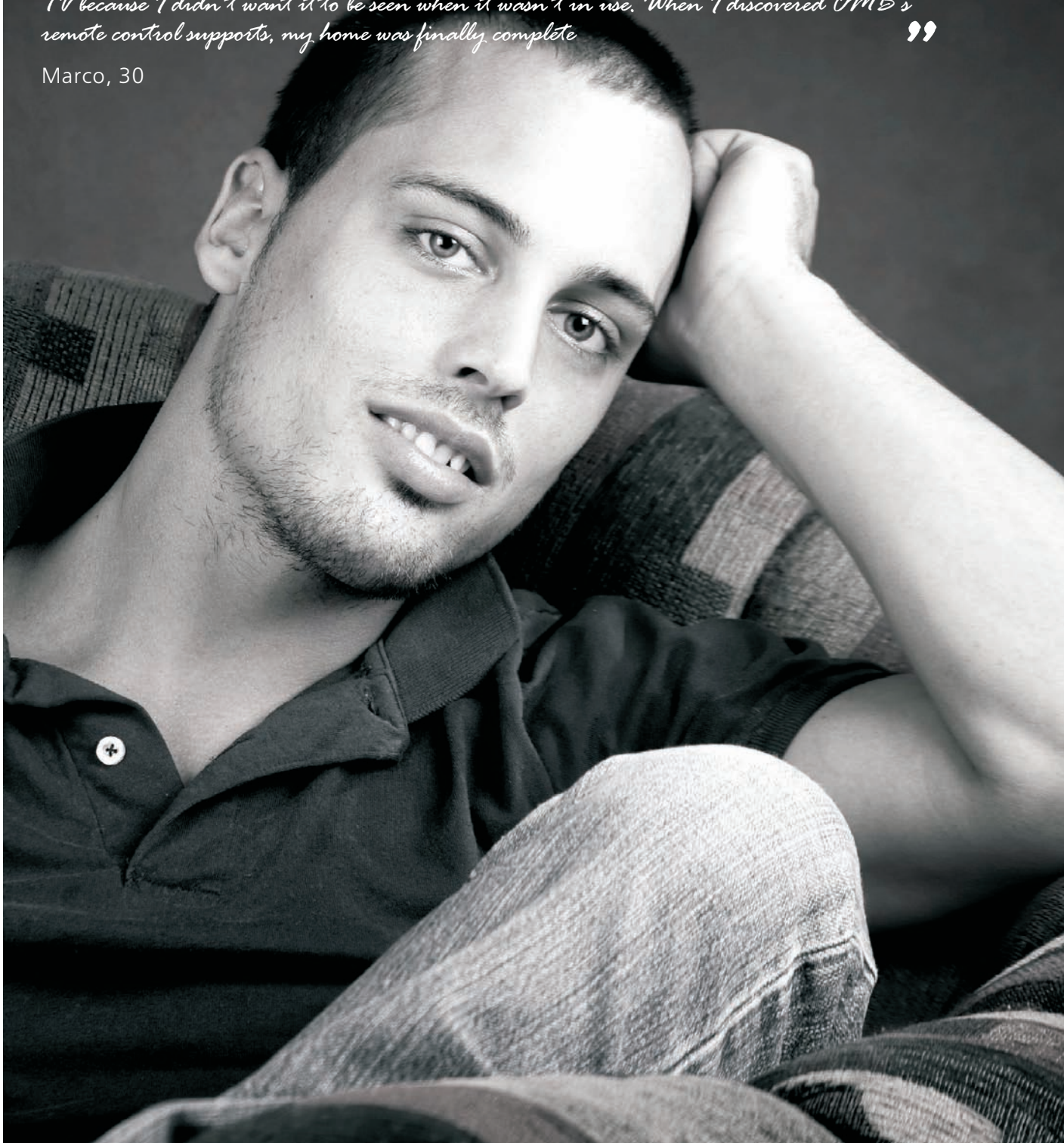

Electric supports

I supporti elettrici sono la grande proposta per avere sempre la visuale perfetta, da ogni angolazione ed in tempo reale. Una sensazione riequilibrio, di benessere che ti segue ovunque. E, allo stesso tempo, un valido aiuto per soluzioni particolari in tutti tipi di arredamento.

OMB's motorized supports are the great solution for a perfect vision from every angle in real time. A sense of well-being and readjustment that follows you everywhere, and, at the same time, a valid help for individual solutions in any type of ambient.

37 - 52"
94 - 132 cm50 kg max.
110 lbs max.83
mm

REMOTE TILT

1

col.

06150 MAX VESA 600x400

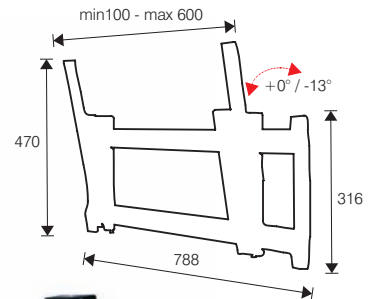

REMOTE TILT

Inclinazione	Su: 0° / Giù : 13°
Modalità automatica	Funzioni Acceso/Spento
Programmazione	2 (5° /9°, meccanico)
Input di controllo	Telecomando Learnable IR e/o Cavo ottico
Corrente	DC12V, 110 – 240 volts (auto allineamento)
Garanzia	1 anno (pezzi & manodopera)
Certificazione	CE, (UL, TUV – in corso di concessione)
Tipologia	Dotato di sistema automatico per la gestione delle funzioni di inclinazione in su & in giù azionabile tramite telecomando Learnable IR. Facile da installare & Design compatto

REMOTE TILT

Tilt Range	Up:0° / Down:13°
Auto Mode	Auto Mode On/Off Function
Preset	2(5° /9°, mechanical)
Control Inputs	Learnable IR Remote and/or Optical Cable
Power	DC12V, 110 - 240 volts(auto-ranging)
Warranty	1 Year(parts&labor)
Certification	CE,(UL, TUV-Pending)
Characteristics	Automatic Tilt up&down with a TV remote Learnable IR Remote Easy Installation & Compact Design

Remote Tilt è una staffa automatizzata per Plasma, LCD e LED che inclina automaticamente il monitor in giù quando il TV è "ACCESO" e lo fa ritornare alla sua posizione eretta quando è "SPENTO". Ha una linea compatta e il telecomando è un optional dato che l'utente può usare il telecomando del TV per l'azionamento e la gestione delle funzioni di inclinazione in su & in giù del monitor. Questo modello permette di sostituire le staffe manuali ad un prezzo ragionevole.

Remote Tilt is an automated tilt mount that automatically tilts the plasma, LCD or LED TV down when the TV is turned "ON" and returns the TV to the upright position when the TV is turned "OFF". It has a compact design and the remote control is an optional as the viewer can use the existing TV remote for the automatic tilt down & up. It is a distribution model to replace manual tilt mount with a reasonable price.

REMOTE SWING 1

32-42"
82-107cm

40kg max.
88 lbs max.

50 mm

col. 06151 MAX VESA 600x400

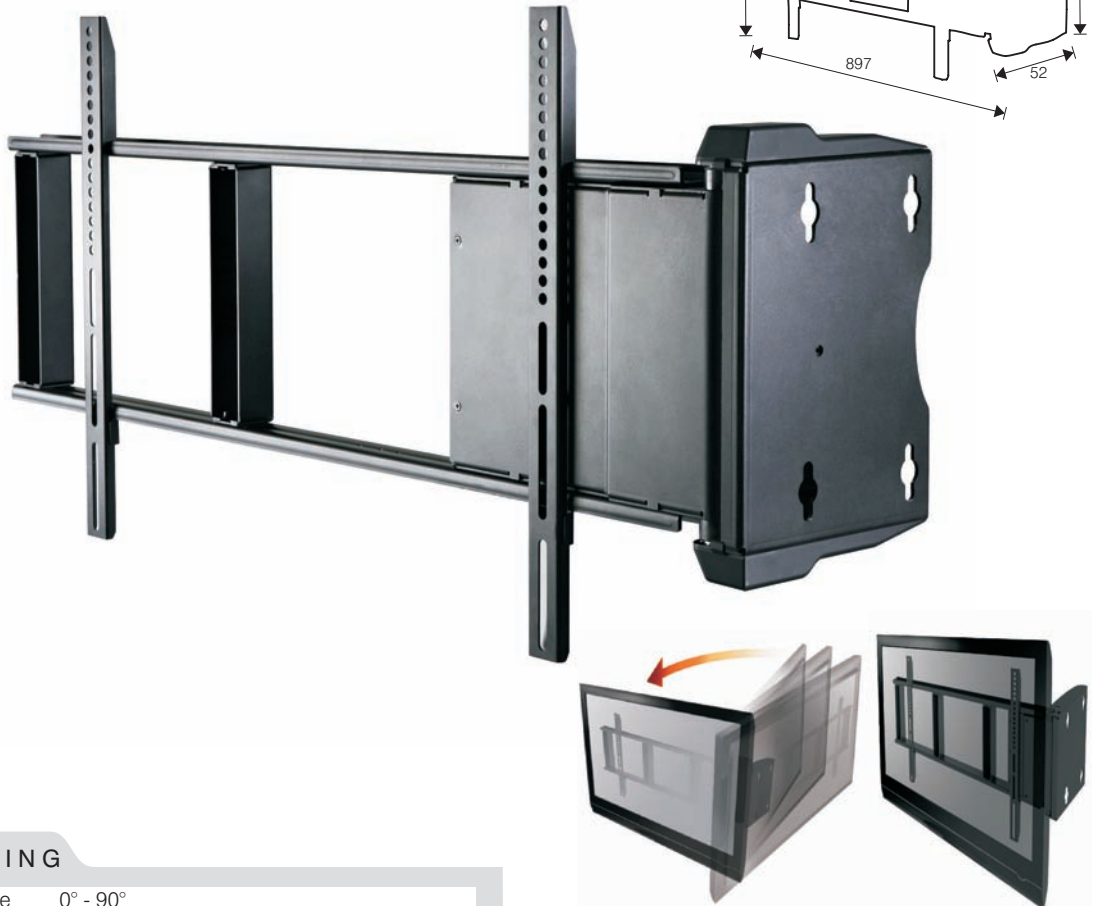
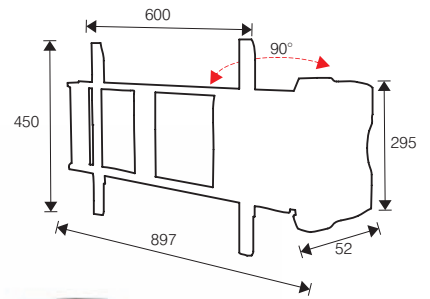

REMOTE SWING

Campo d'oscillazione	0° - 90°
Programmazione	1
Input di controllo	Telecomando Learnable IR
Alimentazione	DC 12V , 110 – 240 volts (auto allineamento)
Garanzia	1 anno (pezzi e manodopera)
Certificazione	CE, (UL, TUV – in corso di concessione)
Tipologia	Staffa con oscillazione automatica Funzione di protezione di sicurezza Design salva-spazio

REMOTE SWING

Swing Range	0° ~ 90° (Automatic)
Preset	1
Control Inputs	Learnable IR Remote
Power	DC 12V, 110 - 240 volts(auto-ranging)
Warranty	1 Year(parts&labor)
Certification	CE,(UL, TUV-Pending)
Characteristics	Automatic Swing Mount Safety Protection Function Space-saving Design

Remote Swing compatibile con LCD, Plasma e LED, è una valida alternativa alla staffa snodata manuale. Può essere montata per oscillare a destra o a sinistra con un campo d'oscillazione di 90° variabile consentendo la visione del Tv da varie angolazioni. Inoltre, può essere montata negli angoli della stanza per utilizzare efficacemente gli spazi.

Remote Swing is a unique alternative to today's manual articulating mounts. It can be mounted to swing either to the left or right with variable 90° swing range which means the TV viewer can watch TV from different angles such as dining room. It also can be installed at the corner of living room to use the space effectively. Suitable for plasma, LCD and LED TVs.

Electric supports

New LED, LCD Plasma supports

The ultimate design

More LED, LCD Plasma supports

Projector supports

Classic TV supports

Audio supports

Surfaces



“

Volevo una televisione, nella mia piccola stanza, per seguire le lezioni di spagnolo senza quel rompiscatole di mio fratello. Solo che non riuscivo ad individuare il posto dove collocarla. E i miei: niente posto, niente Tv. Poi, in un negozio, ho scoperto i supporti della OMB... così ho trovato un posto nella mia camera. E ho convinto i miei.

I wanted a television in my small bedroom so that I could follow my Spanish lessons without being interrupted by my little brother, but I didn't know where to put it. My parents said "no room, no Tv!". Then one day I found the supports by OMB... I found a place in my bedroom and I convinced my parents

”

Ingrid, 17

New LED, LCD Plasma supports

I supporti per LED, LCD e Plasma rappresentano i “pezzi forti” della nostra produzione. Adattabili ad ogni tipo di contesto sono la soluzione ideale per collocare i video dentro gli spazi della vostra abitazione o del vostro ufficio. I supporti sono robusti, facili da montare, sicuri e versatili. Inoltre con Ledfix e Quick collocare, porre e fissare il televisore nella posizione adatta è un gioco da ragazzi. L'originale sistema di questo supporti fissi da parete garantisce alta qualità e prezzi accessibili a tutti.

The supports for LED, LCD and Plasma are the pièce de résistance of OMB's production: adaptable to any type of ambient, they are the ideal solution for the home and the office. The supports are strong, easy to mount, safe and versatile. Furthermore, Ledfix and Quick Level, with their original quick and easy fixing system, guarantee high quality at affordable prices.

Electric supports

New LED, LCD Plasma supports

The ultimate design

More LED, LCD Plasma supports

Projector supports

Classic TV supports

Audio supports

Surfaces



ALL SIZES

QUICK LEVEL

PATENT PENDING

col.

● 06127 **MIN. VESA 100 - MAX VESA "NO LIMITS"**

Il modo più veloce e facile per posizionare la vostra televisione LED, LCD o plasma.

The quick and easy way to position and level your LED, LCD or plasma TVs



80 kg max.
176 lbs max.



10 mm

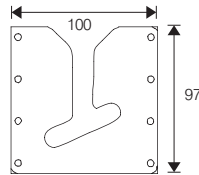
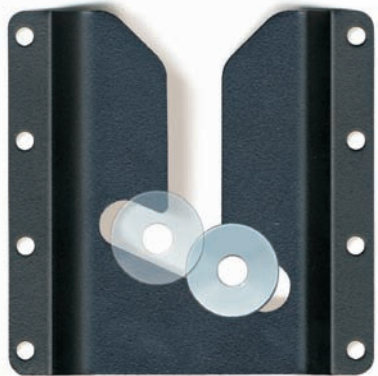

SOLO 10mm. DAL MURO
ONLY 10mm. FROM WALL

SISTEMA LIVELLANTE LEVELLING SYSTEM





ALL SIZES

LEDFIX REGISTERED DESIGN

col. ● 06128 **MIN VESA 200 - MAX VESA 400**

Massimo risultato. Minimo spazio. Per LED TV.
Maximum result in the minimum space. For LED TVs.

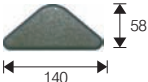

Da applicare al muro / To apply to wall

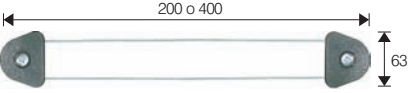

Da applicare al monitor / To apply to monitor

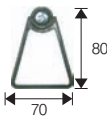

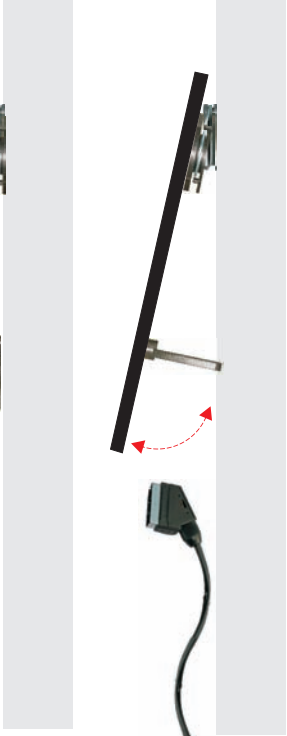

**SISTEMA LIVELLANTE
LEVELLING SYSTEM**

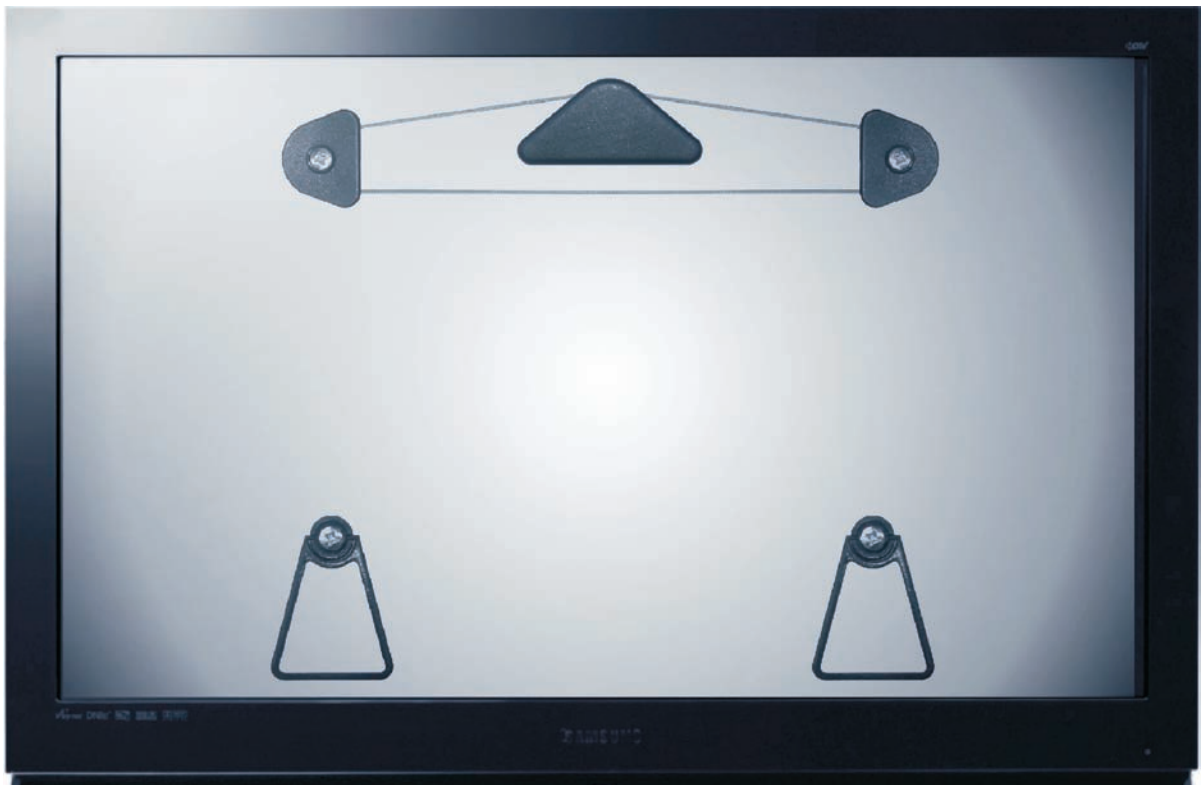

Electric supports

New LED, LCD Plasma supports

The ultimate design

More LED, LCD Plasma supports

Projector supports

Classic TV supports

Audio supports

Surfaces



10-37"
25-94cm



30kg max.
66 lbs max.



55 mm



SLIM 2

REGISTERED DESIGN

2

col.

● 06147 VESA 50/75/100/200x100/150/200

Supporto murale a due snodi, inclinabile per plasma, LCD e LED TV

Inclinabile wall bracket with two articulations for plasma, LCD and LED TV

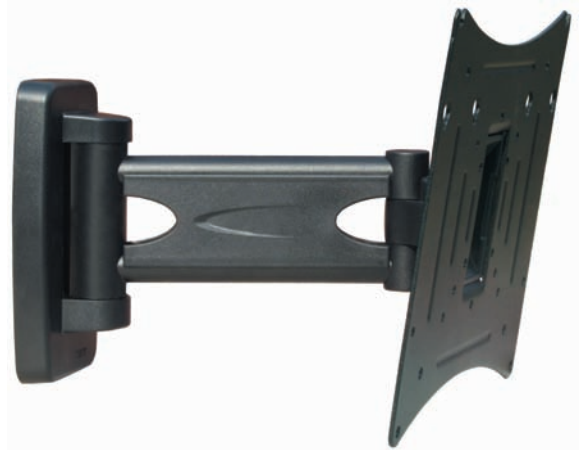
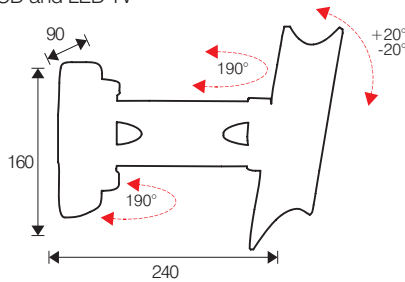

10-37"
25-94cm



30kg max.
66 lbs max.



55 mm



SLIM 3

REGISTERED DESIGN

3

col.

● 06148 VESA 50/75/100/200x100/200

Supporto murale a tre snodi, inclinabile per plasma, LCD e LED TV

Inclinabile wall bracket with three articulations for plasma, LCD and LED TV

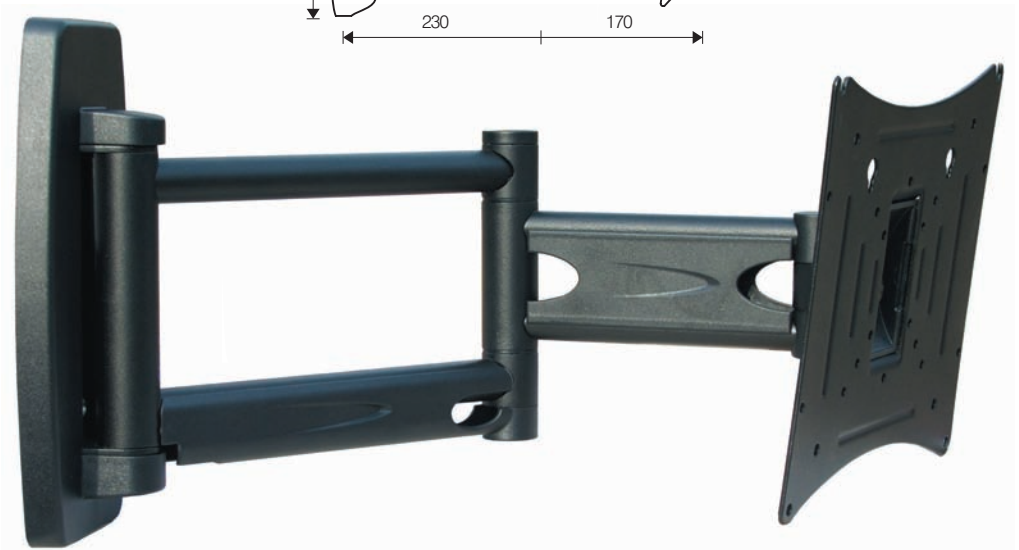
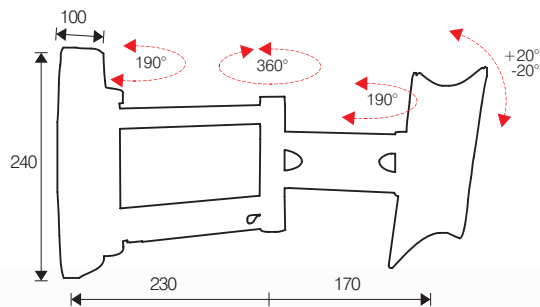



SLIM 600

REGISTERED DESIGN

col.

● 06144 **MAX VESA 600x400**

Supporto universale da parete ad inclinazione fissa per TV al plasma, LED e LCD.

Universal support with a fixed inclination for plasma, LED and LCD TV.

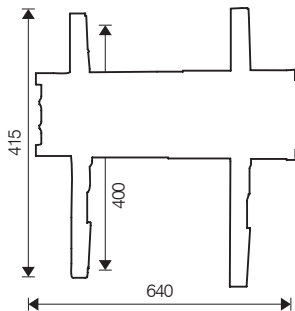

SLIM 800

REGISTERED DESIGN

col.

● 06139 ● 26139 **MAX VESA 800x400**

Supporto universale da parete ad inclinazione fissa per TV al plasma, LED e LCD.

Universal support with a fixed inclination for plasma, LED and LCD TV.

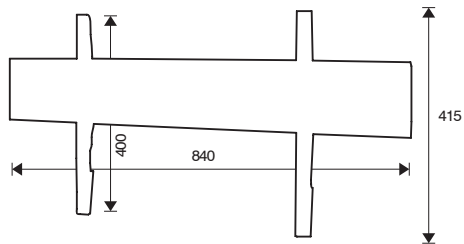

Electric supports

New LED, LCD Plasma supports

The ultimate design

More LED, LCD Plasma supports

Projector supports

Classic TV supports

Audio supports

Surfaces



26-52"
65-130cm

SLIMTILT 600

REGISTERED DESIGN

1

col.

● 06145 MAX VESA 600x400



50kg
110 lbs max.

Supporto universale da parete inclinabile per tv al plasma, LED e LCD.



Universal inclinable wall support for plasma, LED and LCD TV.



35 mm

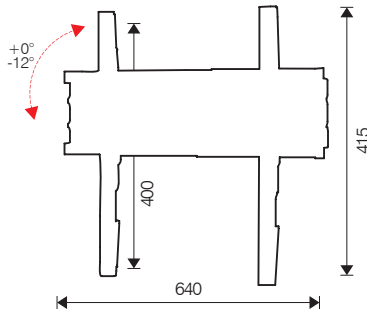
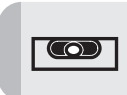

30-63"
76-160cm

SLIMTILT 800

REGISTERED DESIGN

1

col.

● 06129 MAX VESA 800x400

● 26129



60kg max.
132 lbs max.

Supporto universale da parete inclinabile per tv al plasma, LED e LCD.



Universal inclinable wall support for plasma, LED and LCD TV.



35 mm

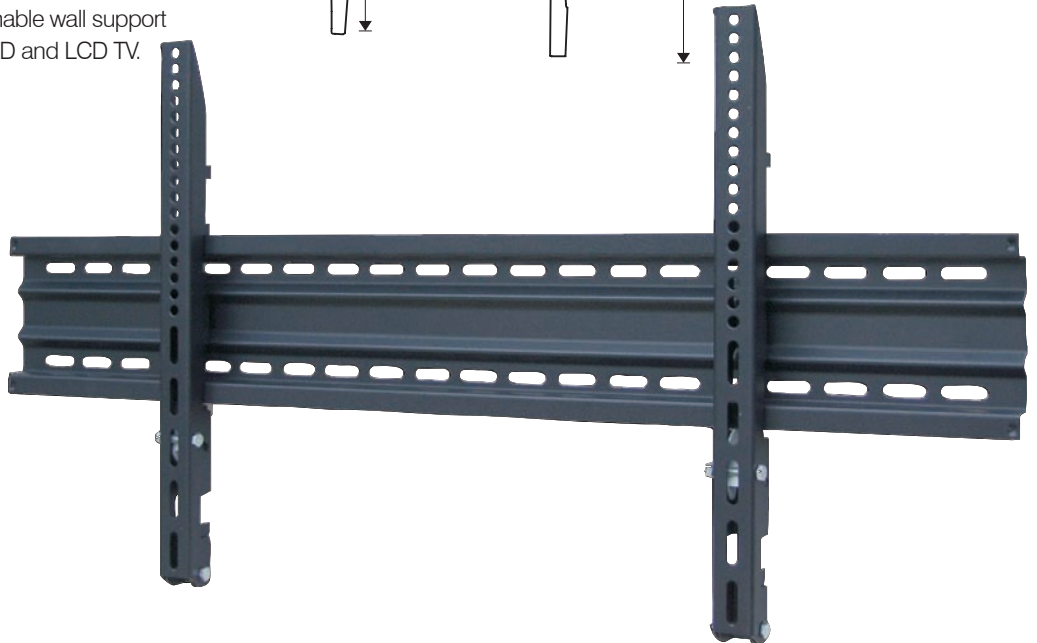
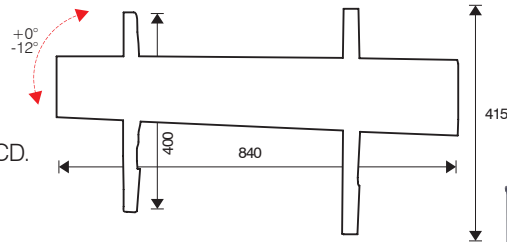



10-32"
25-80cm

SLIM 200

PATENT PENDING



col. 06154 **MAX VESA 200x200**

Supporto universale da parete fisso per TV al plasma, LED e LCD.
 Universal support with a fixed inclination for plasma, LED and LCD TV.



20kg max.
44 lbs max.





12
mm



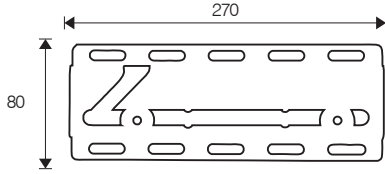







75kg max.
165lbs max.

NEW LIFT

col. 06055
26055

Aggancio a soffitto con rotazione ed estensione da applicare a uno o anche due (uno per lato) SLIM 600/800 - SLIMTILT 600/800*

Rotatable and extendable ceiling arm to apply to one or even two (one on each side) SLIM 600/800 - SLIMTILT 600/800*



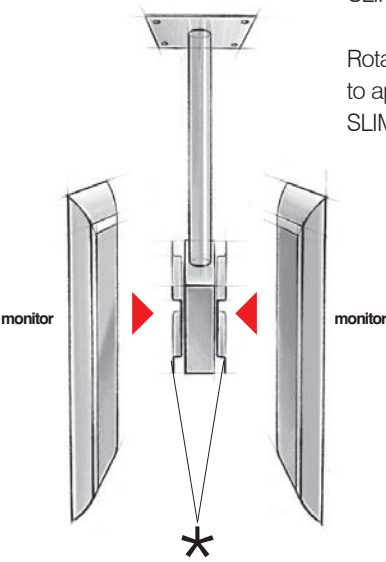



min 600 max 1000

360°

Electric supports

New LED, LCD Plasma supports

The ultimate design

More LED, LCD Plasma supports

Projector supports

Classic TV supports

Audio supports

Surfaces

“

Per il mio studio volevo un supporto per lo schermo della televisione che fosse anche un oggetto di design. I supporti OMB, disegnati da Pininfarina Extra mai hanno convinto subito: eleganti, essenziali, intriganti. A volte ho l'impressione che il supporto sia meglio dello schermo.

For my studio, I wanted a Tv support with a great design. OMB's supports are designed by Pininfarina Extra and when I first saw them I was convinced: elegant, essential and intriguing. I sometimes find myself watching the support instead of the television!"

”

John, 33

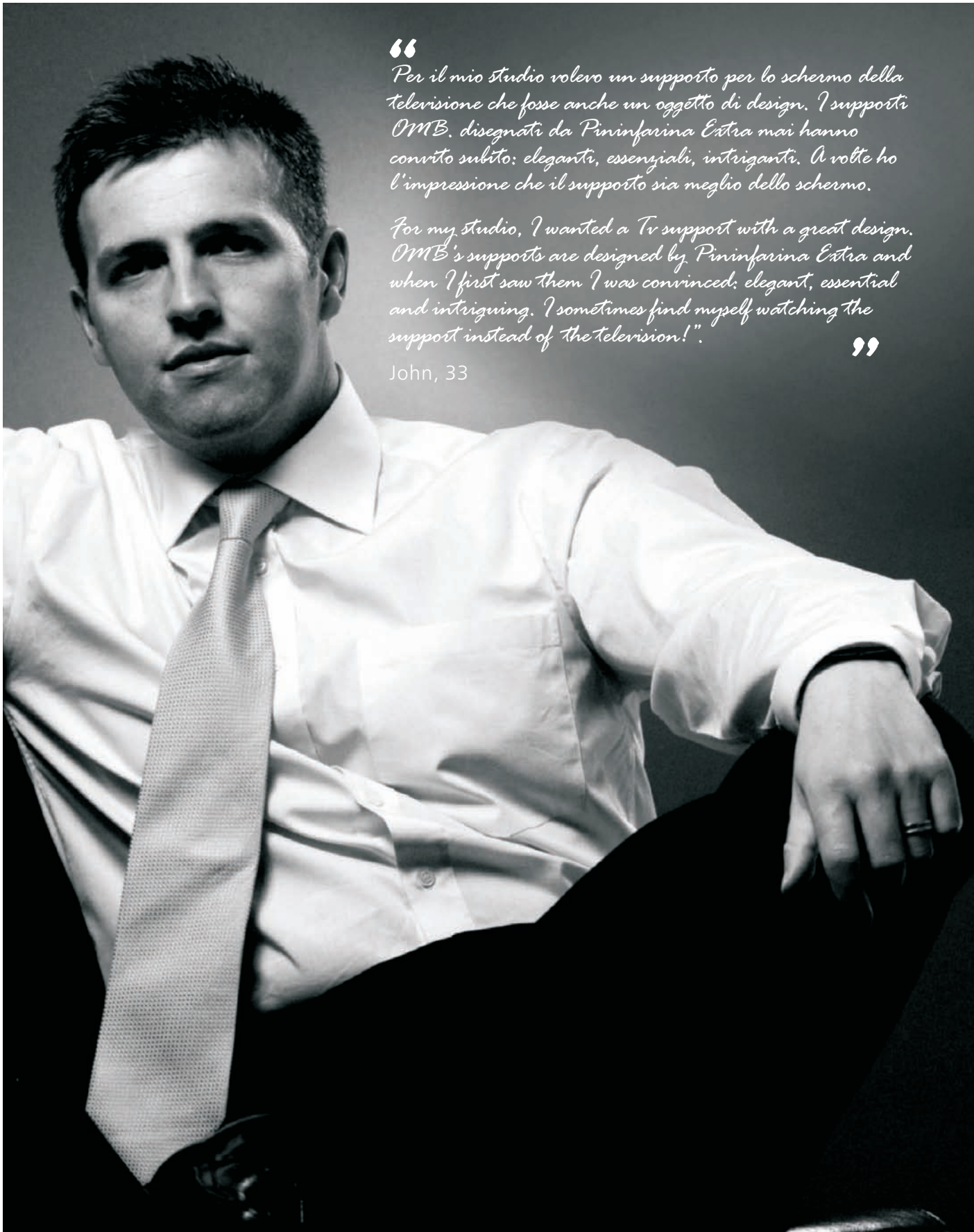



The ultimate design

I supporti OMB disegnati da Pininfarina Extra rappresentano il lato “elegante” della nostra produzione. Sono supporti pensati come veri e propri oggetti di design, intriganti, sinuosi, a loro agio anche dentro gli arredamenti più sofisticati.

OMB's supports designed by Pininfarina Extra are the “elegant” side of the production. They are considered true objects of design, intriguing and at ease with elegant furnishings.

10 - 37"
25 - 94cm30 kg max.
66 lbs max.

116 mm



O - 1

REGISTERED DESIGN

1

col.

06130 VESA 50/75/100/200*100

06131 VESA 50/75/100/200*100/150/200

Supporto murale in alluminio ad uno snodo, inclinabile per TV LED, LCD e plasma.

Evoluzione e rivoluzione! Un design inedito, un materiale di alta qualità, un nuovo sistema di aggancio ad innesto rapido ed immediato: sono questi i punti di forza eccezionali che senza alcuna esitazione collocano il supporto O-ONE tra i primi della sua categoria.

Single joint inclinable aluminium wall mounting for LED, LCD and plasma TVs.

Evolution and revolution! A cutting edge design, high quality material, a new quick, immediate coupling and fixing system - these are the exceptional features that undoubtedly place the O-ONE support among the top units in its category.

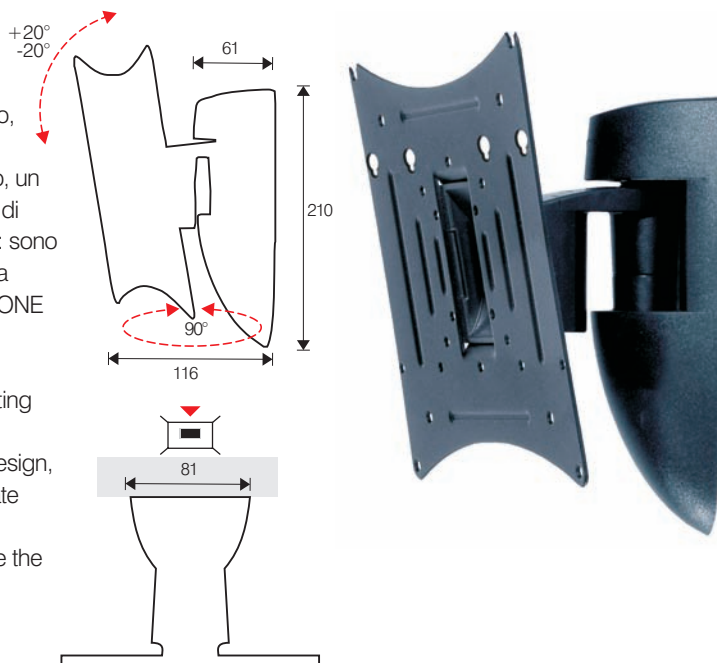
10 - 37"
25 - 94cm30 kg max.
66 lbs max.

117 mm



O - 2

REGISTERED DESIGN

2

col.

06132 VESA 50/75/100/200*100

06133 VESA 50/75/100/200*100/150/200

Supporto murale in alluminio a due snodi, inclinabile per TV LED, LCD e plasma. L'audacia della struttura di O-TWO ha in sé la capacità di trasmettere una percezione di forza e stabilità seppur con uno stile pulito e lineare. Il semplice sistema di aggancio rende intuitivo il suo utilizzo per un'ottimale funzionalità dei due snodi.

Two joint adjustable aluminium wall mounting for LED, LCD and plasma TVs. The very daringness of the O-TWO structure is able to transmit a perception of strength and stability, even with its clean, linear style. The very simply fixing system makes it easy to use and the two joints provide excellent functionality.

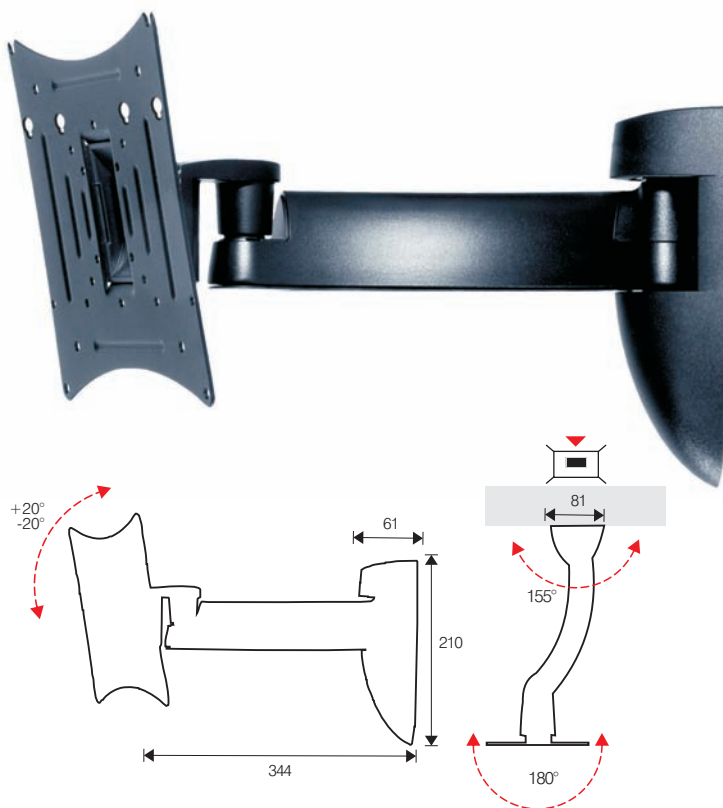



10 - 37"
25 - 94cm



30 kg max.
66 lbs max.



117
mm



O - 3

REGISTERED DESIGN

3

col.



06134 VESA 50/75/100/200*100

06135 VESA 50/75/100/200*100/150/200

Supporto murale in alluminio a tre snodi, inclinabile per per TV LED, LCD e plasma. I tre snodi di O-THREE consentono di andare oltre gli schemi convenzionali dell'arredamento che tradizionalmente prevede il televisore collocato in una posizione fissa: le sensazioni di libertà e benessere ci accompagnano nella scelta della migliore visuale in tutta sicurezza. Un supporto di qualità ed esteticamente piacevole che non delude mai in qualsiasi contesto.

Three joint adjustable aluminium wall mounting for LED, LCD and plasma TVs.

O-THREE's three joints make it possible to go beyond the conventional furnishing schemes that traditionally see the TV located in a set position - the sensation of freedom and wellbeing go hand-in-hand with choosing the best view in complete safety. A quality support that is aesthetically pleasing, and that does not disappoint under any circumstances.

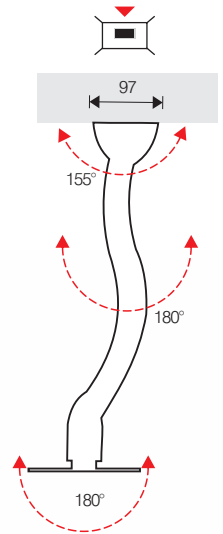
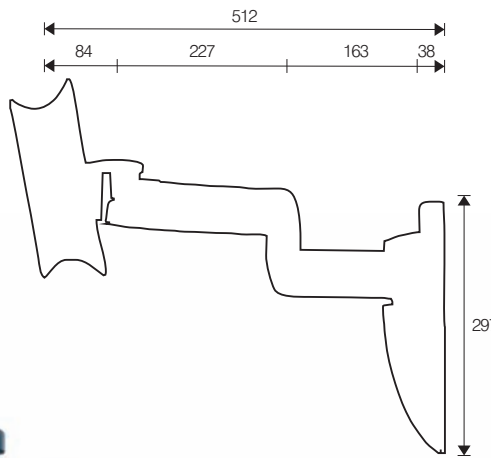

LUNAR TUNNEL



26122



06122

Elemento di collegamento per serie Lunar e O per nascondere i cavi

Connecting element for concealing wires to apply to Lunar and O models

293

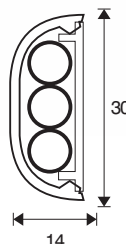

Electric supports

New LED, LCD Plasma supports

The ultimate design

More LED, LCD Plasma supports

Projector supports

Classic TV supports

Audio supports

Surfaces



30-50°
76-127cm



50 kg max.
110 lbs max.



150 mm



O - 4

PATENT PENDING

2

col.



06137 MAX VESA 800x400

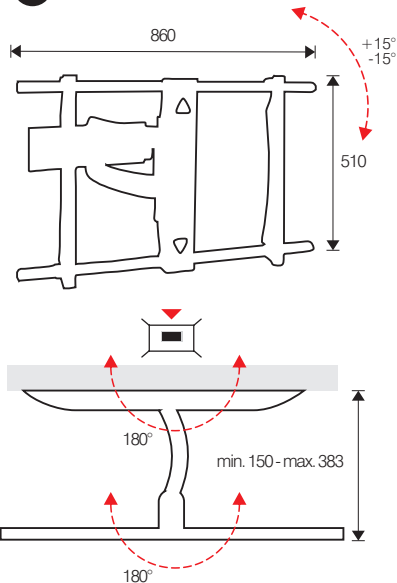

Supporto murale in alluminio e due snodi per TV LED, LCD e plasma.. Accettare le sfide estreme ponendo come obiettivo finale una soluzione senza costrizioni né compromessi ! Un input perfetto per riuscire a dare il meglio di sé. Ed è questa la proposta di O-FOUR, supporto per TV LCD, LED e PLASMA di medie e grandi dimensioni, dall'inconfondibile design forte e sicuro, simbiosi ideale di funzionalità e benessere.

Two joint adjustable aluminium wall mounting for LED, LCD and plasma TVs. Extreme challenges which impose the perfect solution bring the best out everyone. O-FOUR is the result of such a challenge. A support for medium sized and large LCD, LED and plasma TVs with an unmistakable design, expression of strength, security, functionality and luxury.



30 kg max.
66 lbs max.



O - DVD

2

col.



06136

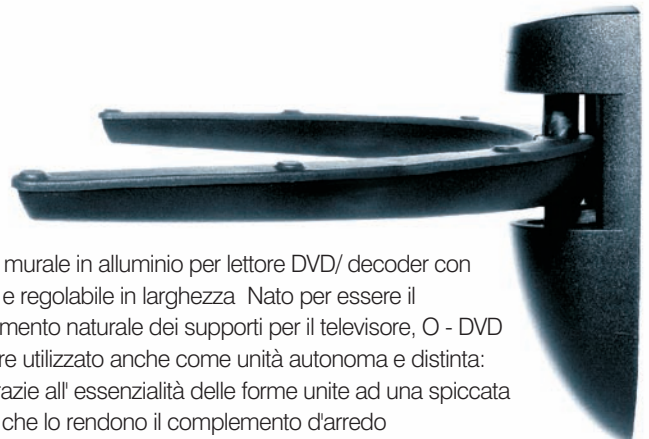
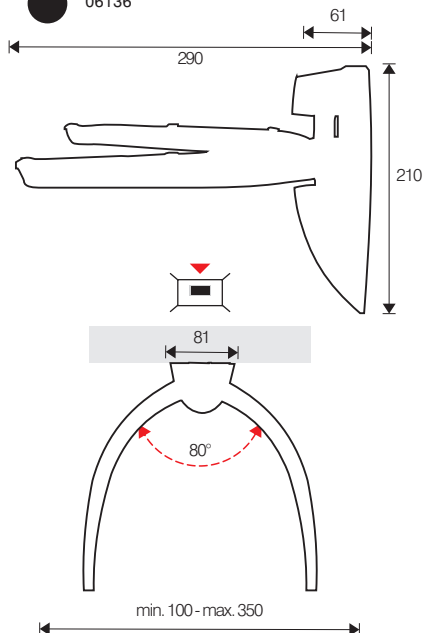

Supporto murale in alluminio per lettore DVD/ decoder con rotazione e regolabile in larghezza. Nato per essere il completamento naturale dei supporti per il televisore, O - DVD può essere utilizzato anche come unità autonoma e distinta: questo grazie all' essenzialità delle forme unite ad una spiccata eleganza che lo rendono il complemento d'arredo indispensabile, facilmente integrabile in ogni situazione.

Rotatable aluminium wall mounting adjustable width wise for decoders and DVDs .Born to complete LCD and Plasma supports, O - DVD can also be used separately, thanks to its essential forms and distinct elegance. These characteristics make it a useful household object easy to integrate in every situation.

creating space beautifully



“

Nella nostra nuova casa abbiamo fatto posto anche per la OMB. E la televisione... vola.

In our new home there's room for OMB. And the Tv.....flies.

”

Xiao, 28 - Asako, 26

00

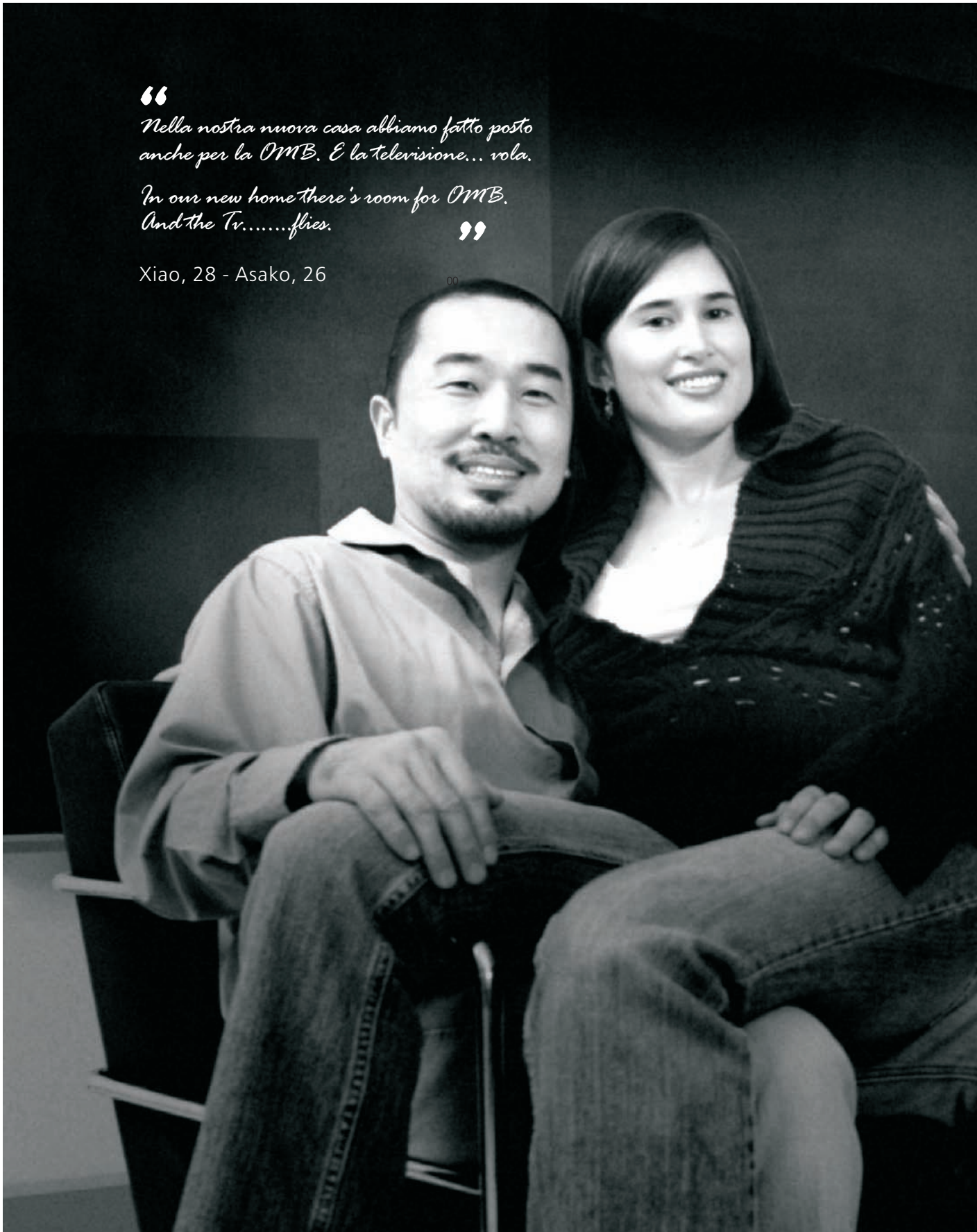

More
LED, LCD
Plasma
supports

I supporti OMB sono versatili e si adattano a tutti i tipi di monitor. Sono semplicissimi per essere fissati agevolmente al posto più adatto della vostra casa.

OMB's supports are versatile and suitable for all types of TVs. They can be easily positioned anywhere in the home.

Electric supports

New LED, LCD Plasma supports

The ultimate design

More LED, LCD Plasma supports

Projector supports

Classic TV supports

Audio supports

Surfaces



10-32"
25-82cm



30kg max.
66 lbs max.



75 mm



LUNAR 1

REGISTERED DESIGN



col. 26105 **VESA 50/75/100/200x100/150/200**
26094 **VESA 50/75/100/200x100**

Supporto murale ad uno snodo, inclinabile per plasma, LCD e LED TV

col. 06105 **VESA 50/75/100/200x100/150/200**
06094 **VESA 50/75/100/200x100**

Inclinabile wall bracket with one articulation for plasma, LCD and LED TVs

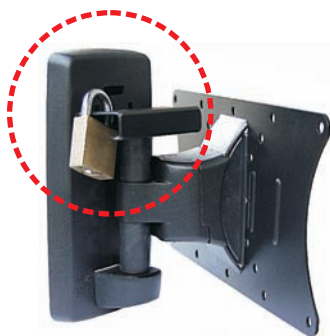
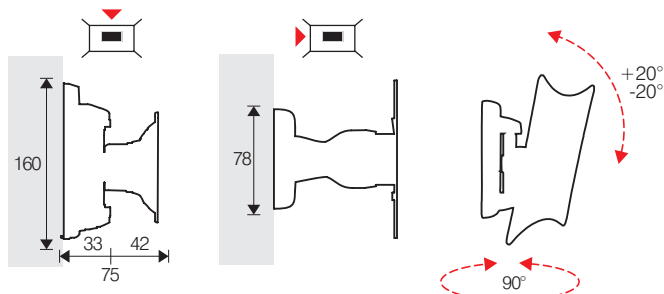

SECURITY KIT LUNAR 1 col. 06095

La sicurezza e il design d'alto livello sono garantiti nel nuovo assetto SECURITY, adattabile a LUNAR1 e LUNAR2. Completo e versatile, una silhouette sottile ma di provata robustezza SECURITY è composto da una piastra di metallo, perfettamente integrabile con la struttura portante, che consente un ulteriore ancoraggio del TV al supporto stesso, dotata anche di lucchetto. E altro plus fondamentale, sono le viti utilizzate per il fissaggio, di tipo speciale, per le quali è necessaria un'apposita chiave, fornita a parte.



M4x10 | M5x10



10-32"
25-82cm



30kg max.
66 lbs max.



55 mm



LUNAR 3

REGISTERED DESIGN

col. 26108 **VESA 50/75/100/200x100/150/200**
26092 **VESA 50/75/100/200x100**

col. 06108 **VESA 50/75/100/200x100/150/200**
06092 **VESA 50/75/100/200x100**

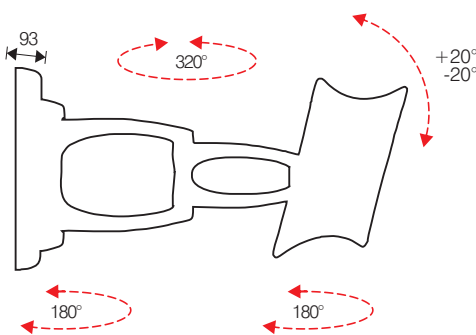
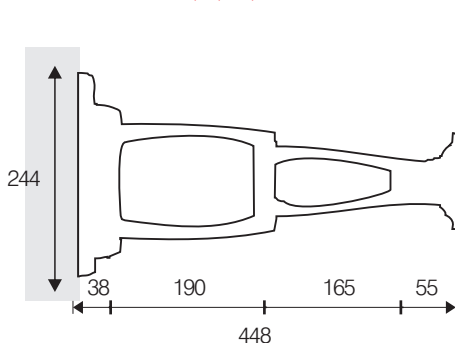

Supporto murale a tre snodi, inclinabile per plasma, LCD e LED TV

Inclinabile wall bracket with three articulations for plasma, LCD and LED TV

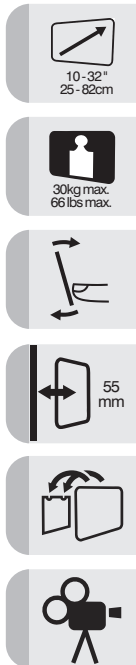

LUNAR 2 REGISTERED DESIGN

- col. 26107 **VESA 50/75/100/200x100/150/200**
 26091 **VESA 50/75/100/200x100**
- col. 06107 **VESA 50/75/100/200x100/150/200**
 06091 **VESA 50/75/100/200x100**

Supporto murale a due snodi, inclinabile per plasma, LCD e LED TV

Inclinabile wall bracket with two articulations for plasma, LCD and LED TV

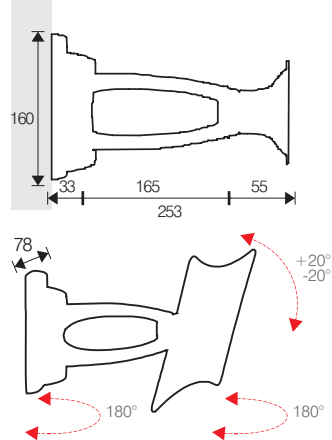

SECURITY KIT LUNAR 2 col. 06096

Safety and top class design come as standard with SECURITY. It combines an elegant and slender silhouette with tested sturdiness and can be adaptable to LUNAR 1 and LUNAR 2. Its metal plate is perfectly integrated to the support and gives the TV extra anchorage. A lock and special screws are supplied, (the latter need a specific spanner which is provided separately).

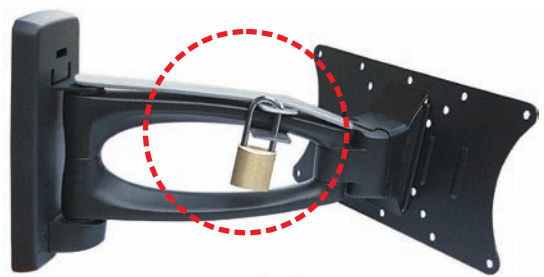

SECURITY KEY



06097





30-50"
76-125cm



50kg max.
110 lbs max.



130
mm



LUNAR REACH

PATENT PENDING

3

col.

● 26093 Max VESA 800 x 400

col.

● 06093 Max VESA 800 x 400

Supporto murale inclinabile a tre snodi per TV al LED, LCD e plasma.

Inclinable wall bracket with 3 articulations for LED, LCD and plasma TV

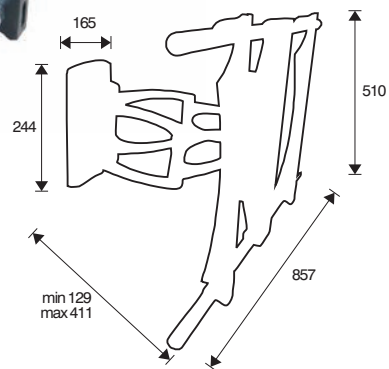
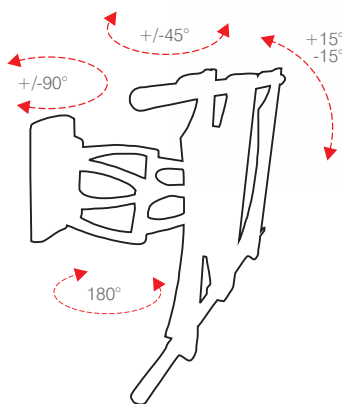

30kg
66 lbs max.



LUNAR DVD

col.

● 26121

col.

● 06121

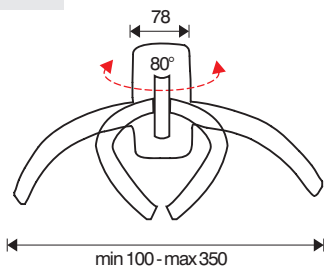
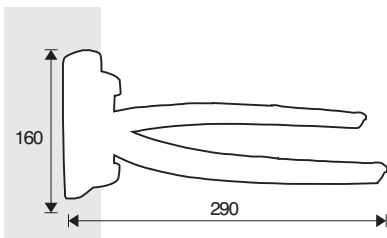

Supporto murale per apparecchiature audio video e hi-fi
Wall support for audio video apparatus

LUNAR GENIO

● 06106

10-37"
25-94cm

30kg max.
66lbs max.

+ LUNAR 1
(06105)

+ LUNAR DVD
(06121)

= LUNAR GENIO

1100

105 mm

30° 90°

“...cavi nascosti e fissaggio sia in orizzontale che verticale”.
“...hidden wires and both vertical and horizontal fixing”

E' sorprendente la funzionalità di Genio che offre **la copertura dei cavi** e massima libertà di fissaggio sia in orizzontale che verticale. Struttura pulita e di testata solidità e sicurezza, forma essenziale ma curata nei dettagli, estetica ricercata, GENIO by OMB è il kit innovativo che abbinando i supporti LUNAR1 e LUNARDVD crea un'accoppiata vincente per un successo garantito.

Genio is functionality at its best! It permits you to **hide wires** and offers both vertical and horizontal fixing. It's clean, linear structure follow the modern aesthetic demands without forgoing the details. GENIO by OMB is the revolutionary kit which, together with LUNAR 1 and LUNARDVD supports creates a winning team for a sure success.

LUNAR POWER

● 06109

LUNAR POWER, dove il design è al servizio della funzionalità! Facile da usare, discreto nella forma LUNAR POWER è la soluzione ideale per contenere e nascondere il collegamento dei cavi alla multipresa (ciabatta inclusa), ma anche quel dettaglio di stile in più per vivere bene e senza pericoli.

LUNAR POWER matches discreet design and functionality. It's easy to use and great for containing and hiding wires connected to the multiple socket. A stylish solution for better and safer living.

265

125 140

**CIABATTA INCLUSA
MULTIPLE SOCKET INCLUDED**

Electric supports

New LED, LCD Plasma supports

The ultimate design

More LED, LCD Plasma supports

Projector supports

Classic TV supports

Audio supports

Surfaces



30 - 63"
76 - 160cm



75kg max.
165lbs max.



90
mm

REACHSTOP

3

col.



06123 Max VESA 800 x 400

Supporto murale a tre snodi per TV al LED, LCD e plasma

Wall bracket with three articulations for LED, LCD and plasma monitors

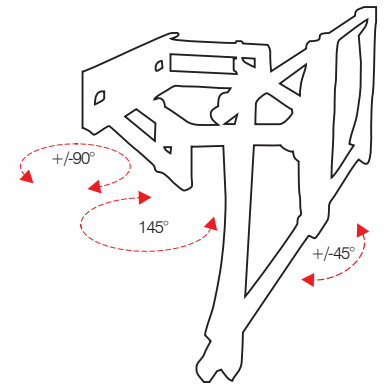
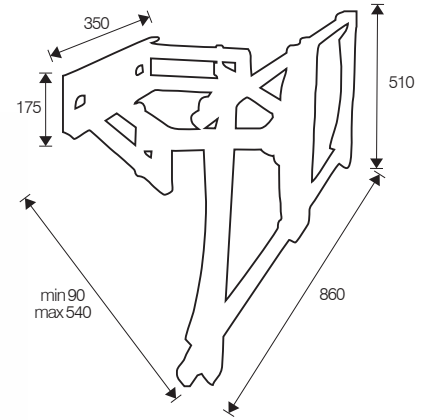

LUNAR TUNNEL

26122 06122

Elemento di collegamento per serie Lunar e serie O per nascondere i cavi

Connecting element for concealing wires to apply to Lunar and O models

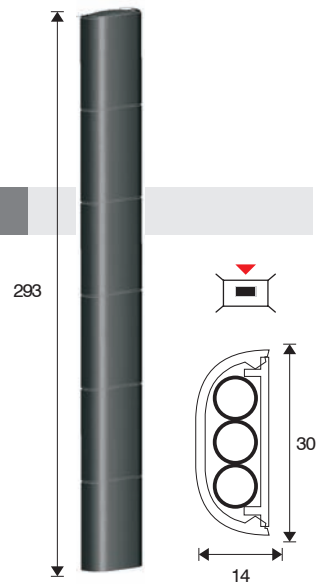



30-63°
76-160cm

REACHGO

PATENT PENDING

3

col.

● 06124 Max VESA 800 x 400

Supporto murale a tre snodi. Inclinabile per TV al LED, LCD e plasma

Inclinable wall bracket with three articulations for LED, LCD and plasma monitors



75kg max.
165lbs max.

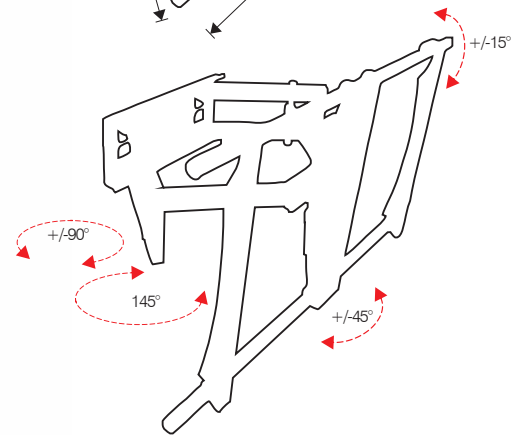
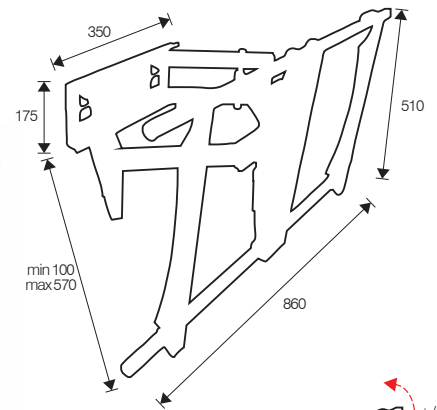

100 mm



ALUM TUNNEL

col.

● 06138

Nasconde i fili degli apparecchi con un sistema modulare personalizzato in **alluminio**, rispondendo così alle ultime tendenze che prediligono modelli funzionali ma di alto design.

This personalized modular system is a stylish solution in **aluminium** designed to hide unsightly wires.

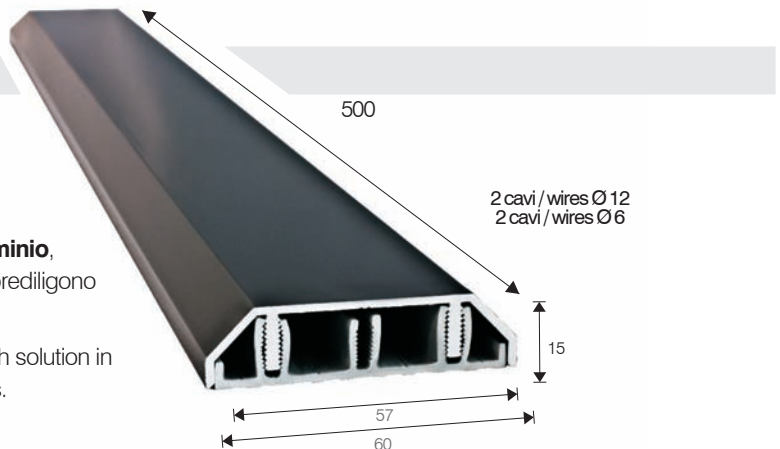



max 32"
max 82cm



20kg max.
44 lbs max.



50 mm

EASYGO 100

REGISTERED DESIGN



col.

● 06142 VESA 50/75/100/200*100

Supporto inclinabile da parete per Lcd e plasma.
Inclining wall bracket for Plasma and LCD.

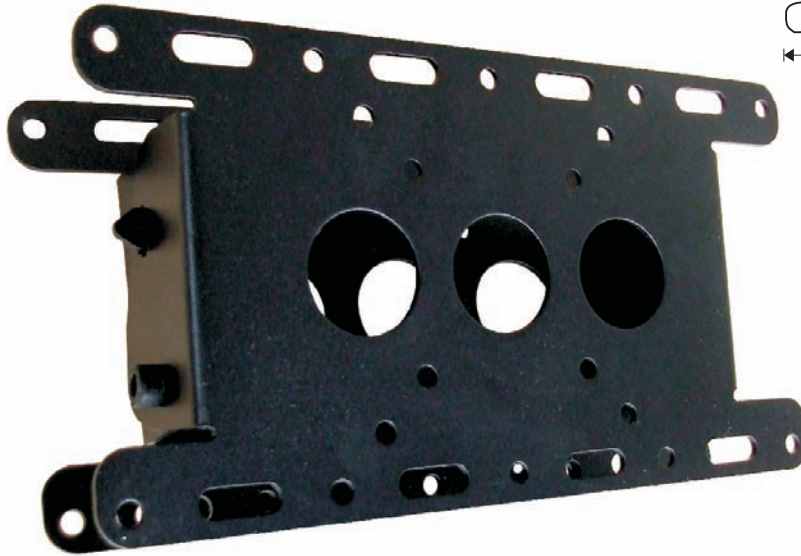
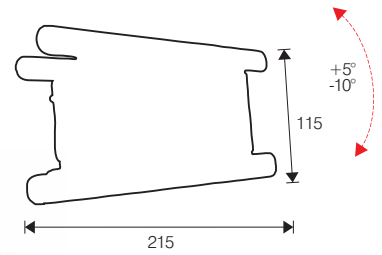

max 40"
max 100cm



25kg max.
55 lbs max.



50 mm

EASYGO 200

REGISTERED DESIGN



col.

● 06143 VESA 50/75/100/200*100/150/200

Supporto inclinabile da parete per Lcd e plasma.
Inclining wall bracket for Plasma and LCD.

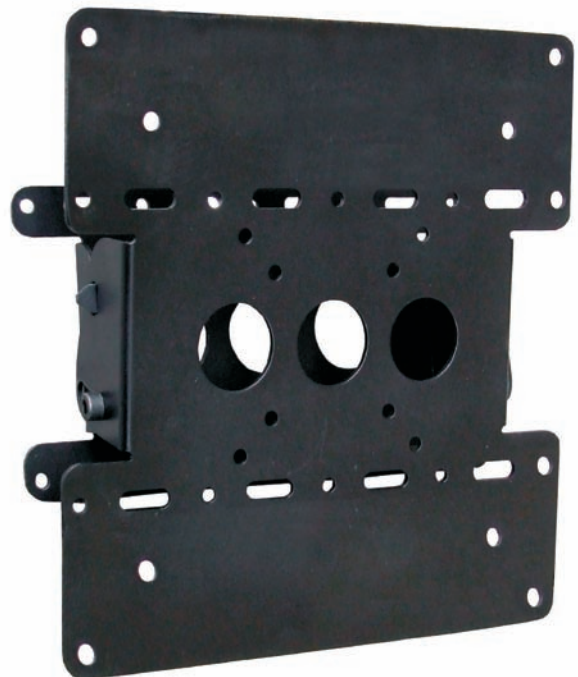
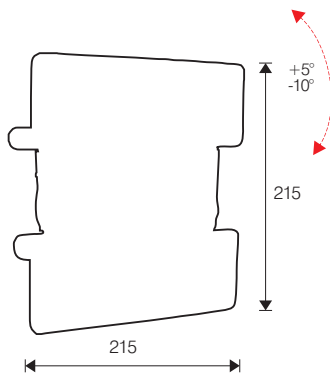



EASYBIG

REGISTERED DESIGN

- col. 26066 Max VESA 800x400 col. 06066 Max VESA 800x400

Supporto per grandi TV al plasma, LED e LCD.
Wall bracket for large plasma, LED and LCD.

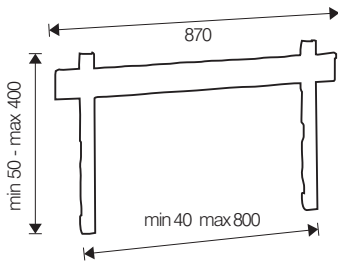

EASYFOUR

REGISTERED DESIGN

- col. 26079 Max VESA 400x400 col. 06079 Max VESA 400x400

Supporto per medie TV al Plasma, LED e LCD.
Wall bracket for medium size Plasma, LED and LCD TVs.

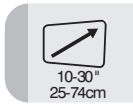
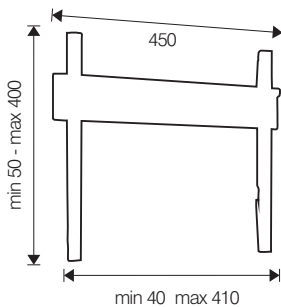

EASYSMALL

REGISTERED DESIGN

- col. 06076 VESA 50/75/100/200x100

Supporto murale per LCD
Wall bracket for LCD.

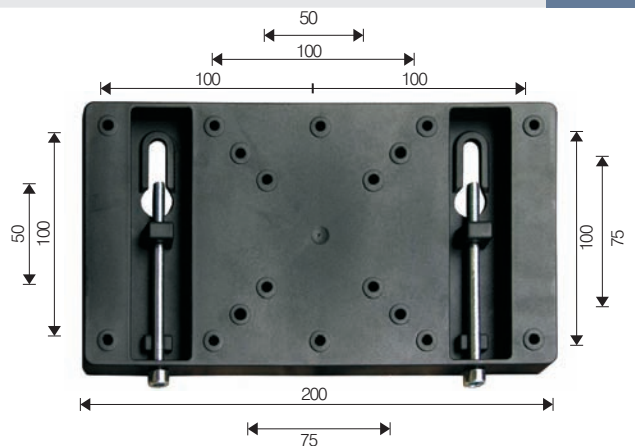



10-32"
25-74cm



20kg max.
44lbs max.



EASYTWO

REGISTERED DESIGN

2

col. ● 26077 VESA 50/75/100/200x100 col. ● 06077 VESA 50/75/100/200x100

Supporto murale a due snodi, inclinabile per LCD / Inclunable wall bracket with two articulations for LCD TV

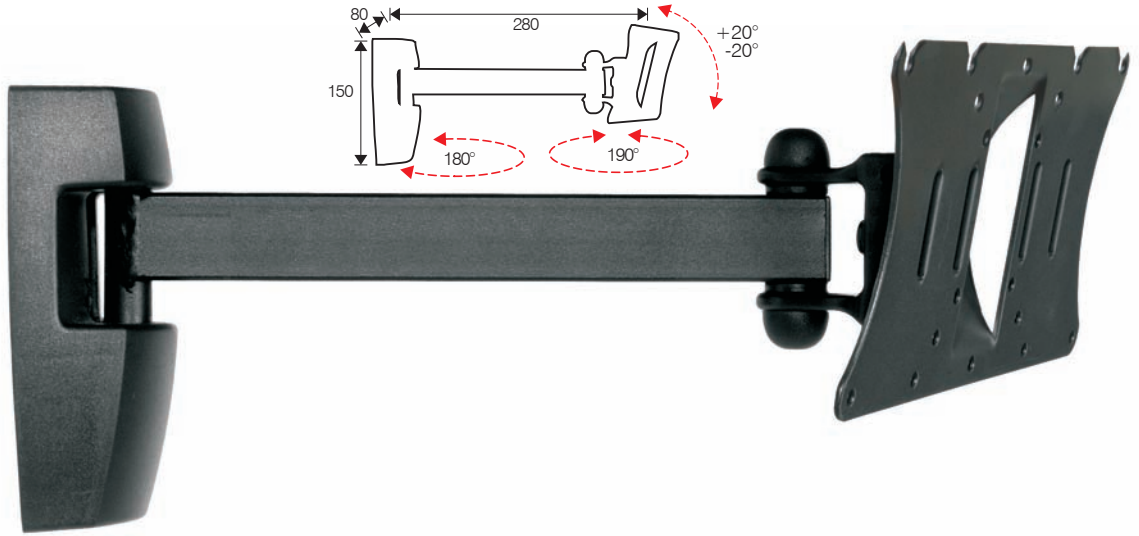

10-32"
25-82cm



30kg max.
66lbs max.



EASYTWO EXTRA

col. ● 26114 VESA 50/75/100/200x100 col. ● 06114 VESA 50/75/100/200x100
 col. ● 26115 VESA 50/75/100/200x100/150/200 col. ● 06115 VESA 50/75/100/200x100/150/200

Supporto murale a due snodi, inclinabile per LCD / Inclunable wall bracket with two articulations for LCD TV

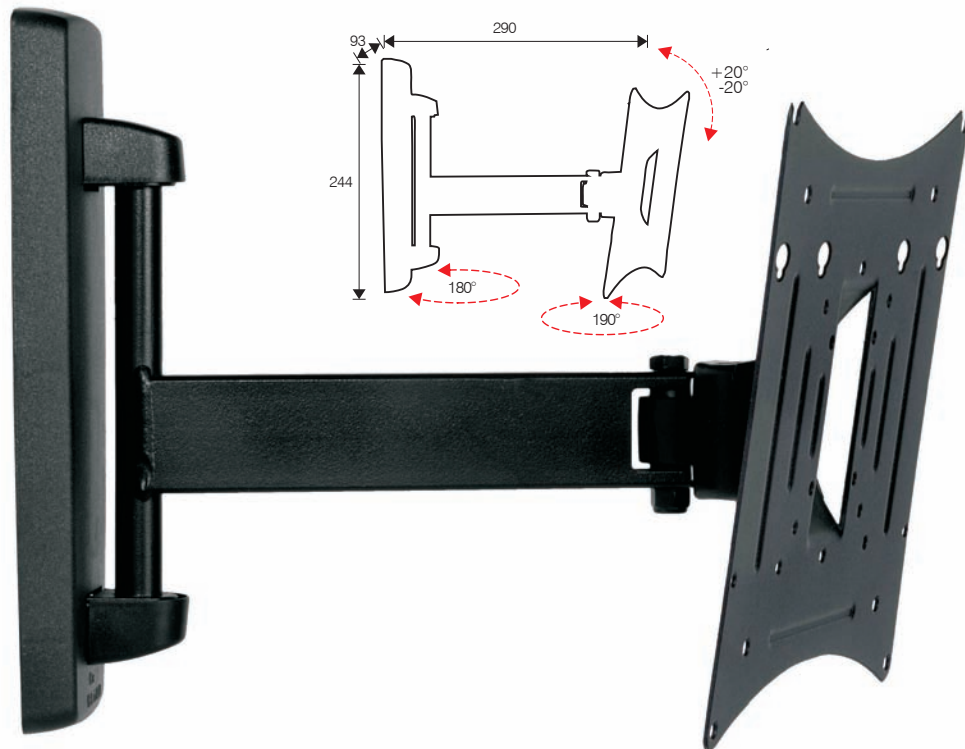

2



10-32"
25-74cm

EASYTHREE

REGISTERED DESIGN



col. ● 26078 VESA 50/75/100/200x100

col. ● 06078 VESA 50/75/100/200x100

Supporto murale a tre snodi, inclinabile per LCD
Inclinable wall bracket with three articulations for LCD TV

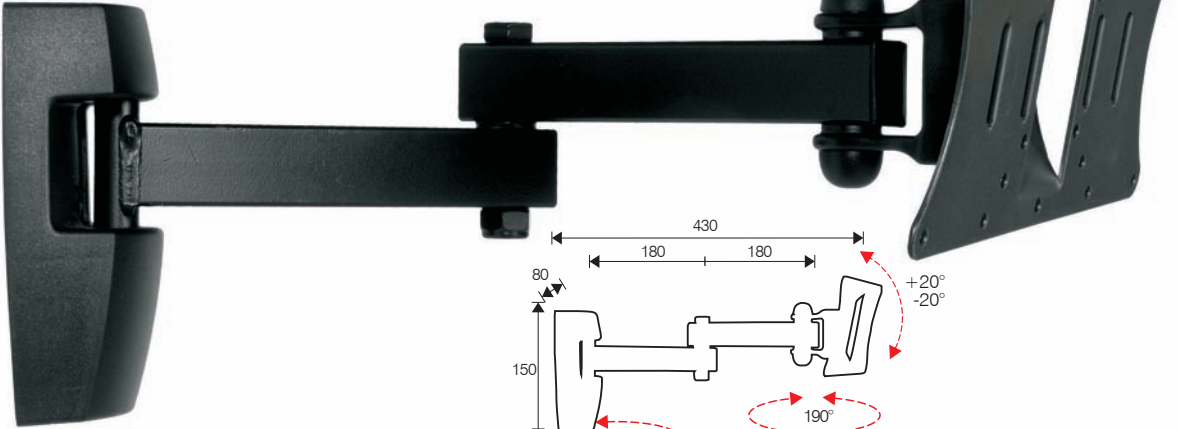
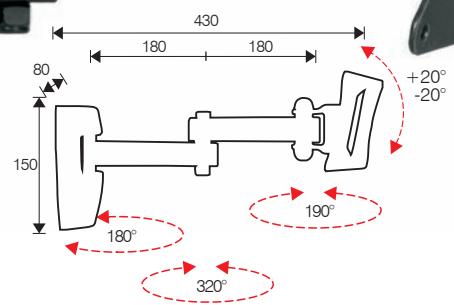

10-32"
25-82cm

EASYTHREE EXTRA



col. ● 26116 VESA 50/75/100/200x100

col. ● 06116 VESA 50/75/100/200x100

col. ● 26117 VESA 50/75/100/200x100/150/200

col. ● 06117 VESA 50/75/100/200x100/150/200

Supporto murale a tre snodi, inclinabile per LCD
Inclinable wall bracket with three articulations for LCD TV

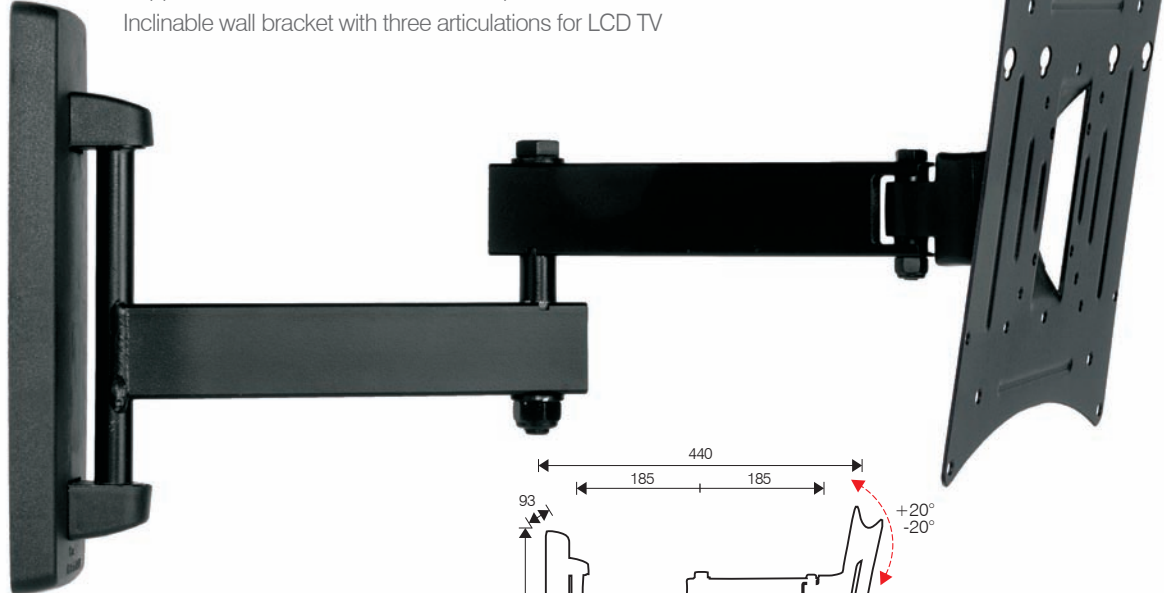
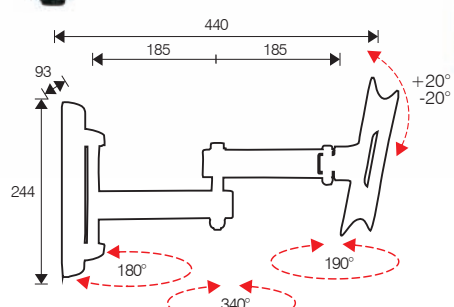
20-40"
50-100cm35kg max.
77lbs max.

80 mm



EASYTHREE 400

3

col.

06118 MAX VESA 400X400

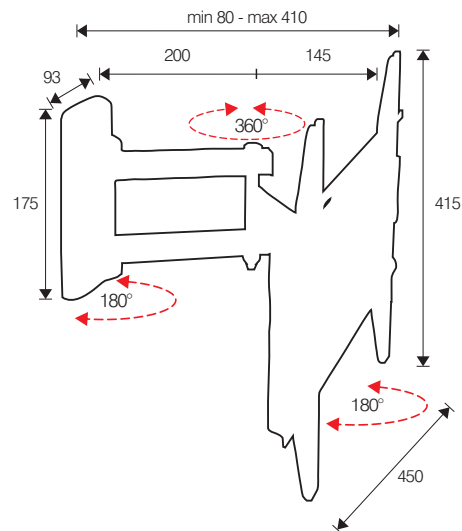

Punto d'attrazione di EASYTHREE400 e EASYTHREE800 è senz'altro l'innovativo attacco vesa per plasma, LED e LCD TV che rende questo modello perfetto per chi cerca prestazioni di alto livello di efficienza e funzionalità ma anche con forte valenza estetica.

EASYTHREE400 and EASYTHREE800 are particularly attractive thanks to their innovative vesa connection for plasma, LED and LCD TV which combines elegant design with high levels of functionality and efficiency.

37-63"
94-160cm45kg max.
99lbs max.

80 mm



EASYTHREE 800

3

col.

06149 MAX VESA 800X400

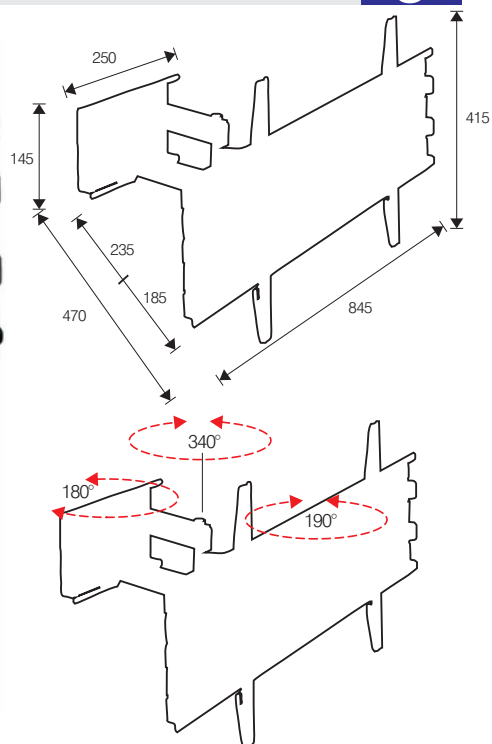

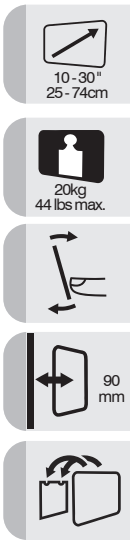

MONOSOLUTION REGISTERED DESIGN 1

- col. 26070 VESA 50/75/100/200x100
 26100 VESA 50/75/100/200x100/150/200
- col. 06070 VESA 50/75/100/200x100
 36070 VESA 50/75/100/200x100/150/200

Supporto murale ad uno snodo, inclinabile per TV LCD.
 Inclined wall bracket with one articulation for LCD TV.

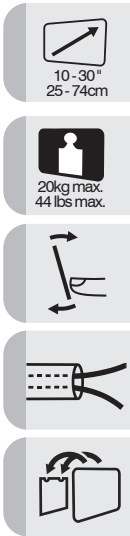
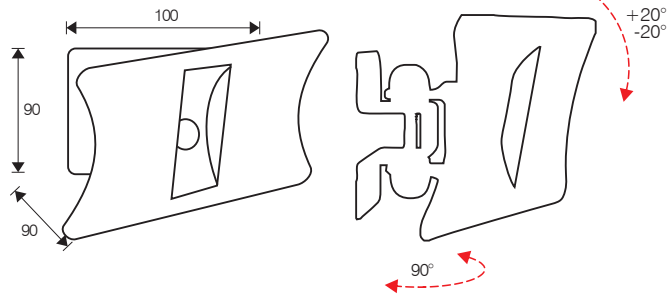

HISOLUTION REGISTERED DESIGN 1

- col. 26073 VESA 50/75/100/200x100
 26103 VESA 50/75/100/200x100/150/200
- col. 06073 VESA 50/75/100/200x100
 06103 VESA 50/75/100/200x100/150/200

Supporto da soffitto ad uno snodo, inclinabile per TV LCD

Inclinable ceiling bracket with one articulation for LCD TV

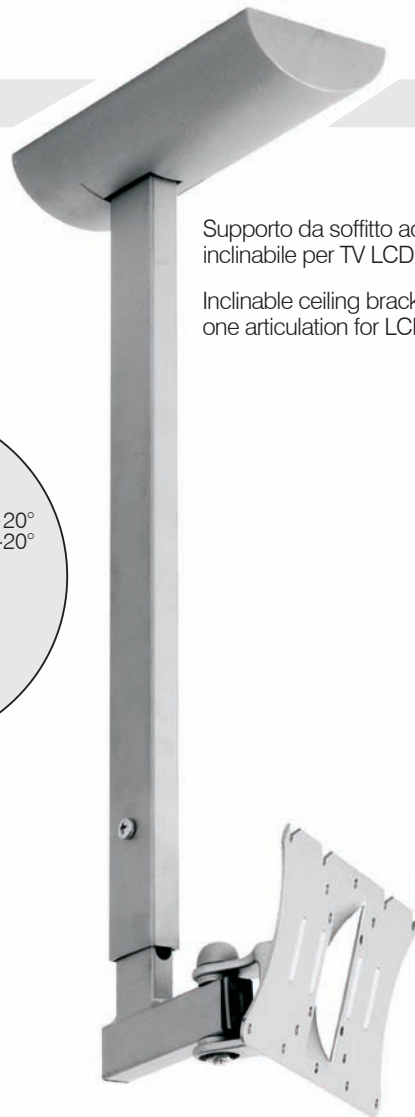
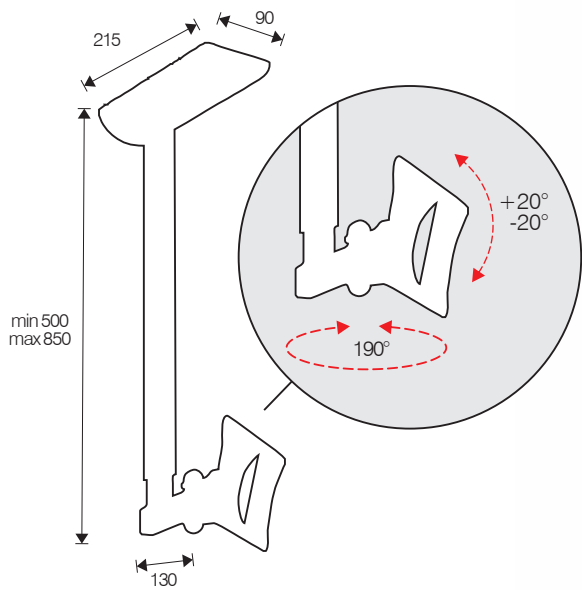

BISOLUTION

REGISTERED DESIGN



10-30°
25-74cm



20kg max.
44 lbs max.



col. 26071 VESA 50/75/100/200x100
26101 VESA 50/75/100/200x100/150/200

col. 06071 VESA 50/75/100/200x100
06101 VESA 50/75/100/200x100/150/200

Supporto murale a due snodi,
inclinabile per TV LCD.

Inclinabile wall bracket with two
articulations for LCD TV.

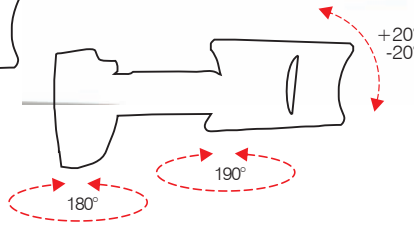
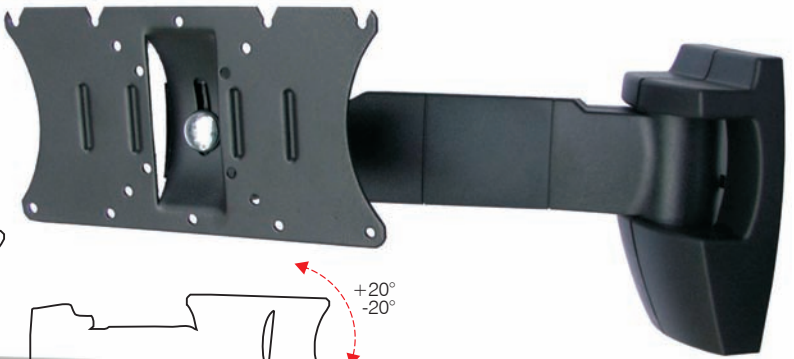
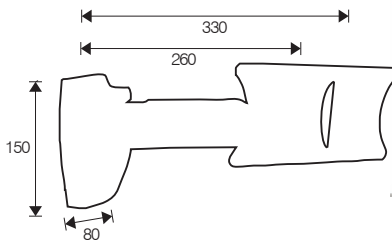

10-30°
25-74cm



20kg max.
44 lbs max.



TRISOLUTION

REGISTERED DESIGN

col. 26072 VESA 50/75/100/200x100
26102 VESA 50/75/100/200x100/150/200

col. 36072 VESA 50/75/100/200x100
06102 VESA 50/75/100/200x100/150/200

Supporto murale a tre snodi,
inclinabile per TV LCD.

Inclinabile wall bracket with three
articulations for LCD TV.

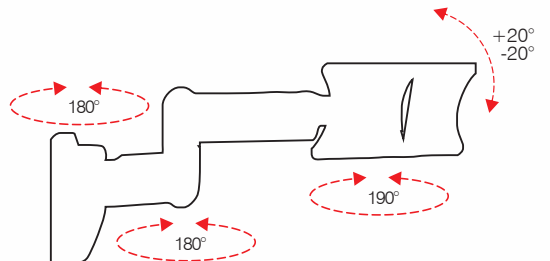
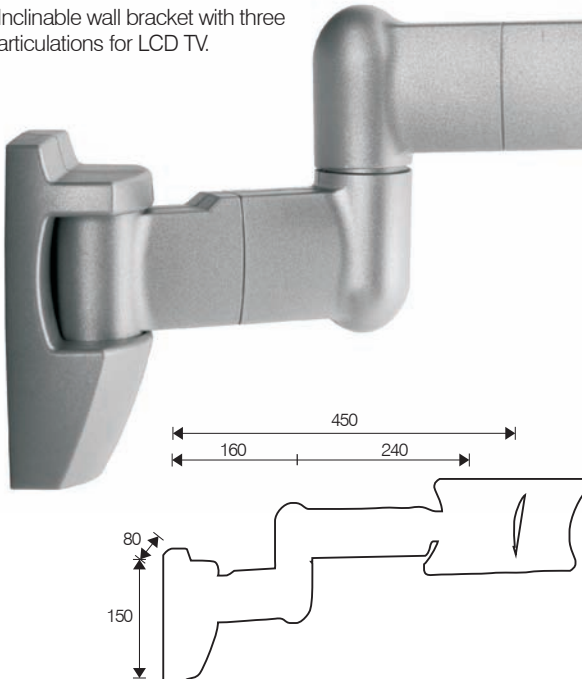



50"
125cm



50kg max.
110 lbs max.



NEW MAGELLANO

col.

● 06104

Carelo professionale per televisori LCD, plasma e LED.
Prowvisto di 4 ruote. Possibilità di aggiungere 2 supporti Lunar DVD.

Professional trolley for LCD, LED and plasma monitors.
Complete with 4 wheels. Can accomodate 2 Lunar DVD supports.

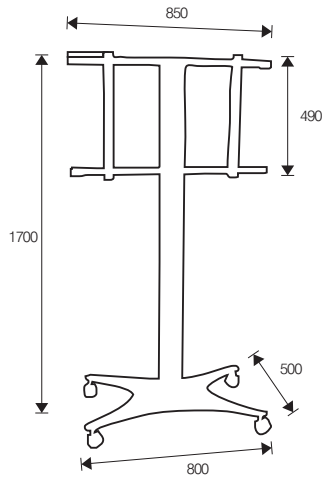
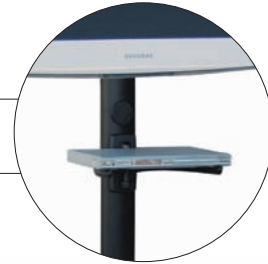

NEW MAGELLANO SHELF

Video Conference accessory



3 kg max.
7 lbs max.

col.

● 06153

Piano superiore da 22 x 15cm
adatto al posizionamento di
una telecamera per
videoconferenze

A superior plane measuring
22 x 15cm suitable for
positioning a television
camera for videoconferences



1.5kg max.
3.85 lbs max.**DVD TRAVEL**

REGISTERED DESIGN

col.

● 06200

Supporto da agganciare al sedile anteriore che permette ai passeggeri seduti dietro di usare il lettore DVD in tutta sicurezza e libertà.

A support to apply to the back of the front seats so that the passengers behind can use freely their portable DVD in total safety.

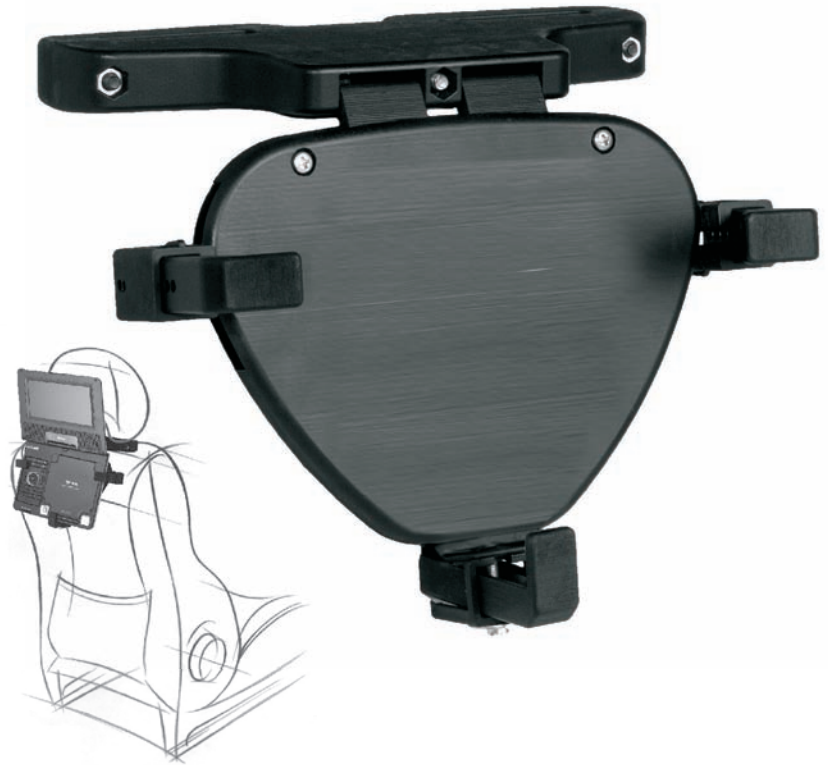
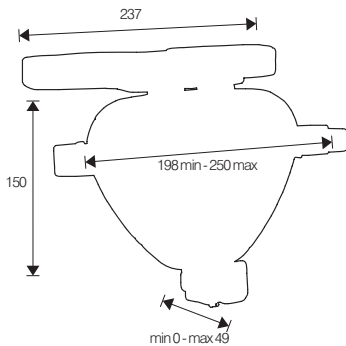
10-20"
25-50cm5kg max.
11 lbs max.**OYSTER**

REGISTERED DESIGN

col.

● 26075 VESA 50/75/100

Supporto "sotto pensile" ad uno snodo, inclinabile per TV LCD

"Under cabinet" support with one articulation for LCD TV

ADATTATORI TV DISPONIBILI SU RICHIESTA
TV ADAPTERS AVAILABLE ON REQUEST

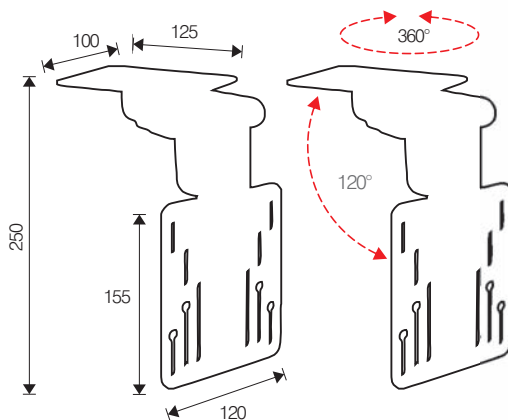



min 10 max 40"
min 25 max 100cm



30kg max.
66lbs max.



60 mm

DECODER BOX

col.



06120 Vesa 75/100/200*100/200*200

Supporto porta decoder da posizionare direttamente dietro la TV.
Decoder support to place directly behind the television.

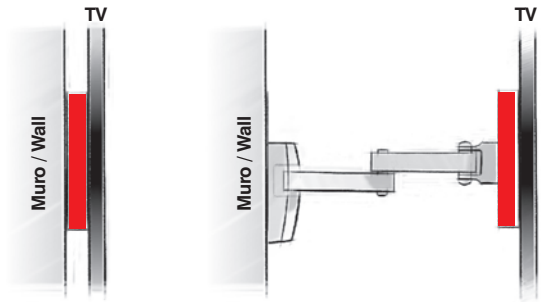
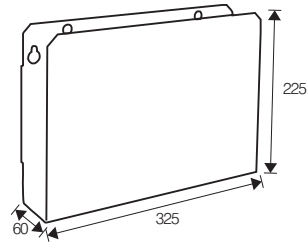
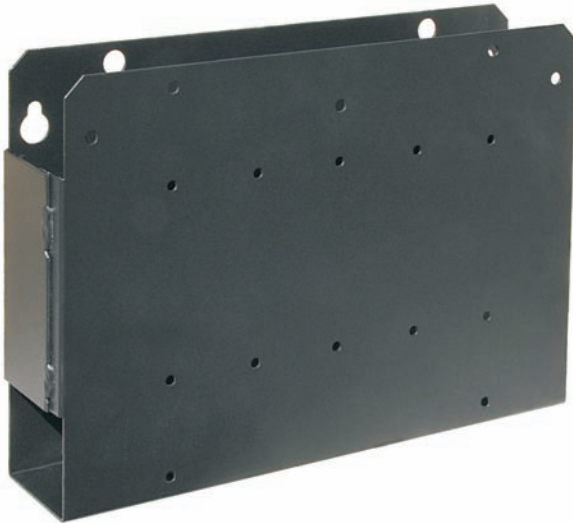

Da fissare direttamente sul muro o ad un supporto
To fix directly on wall or to a support



30kg max.
66 lbs max.

UNIVERSAL ADAPTOR

col.



26088

col.



36088

Adattatore per convertire
VESA 100 fino a VESA 400 x 400.
Adatto anche per televisori LED.

Adaptor for converting
VESA 100 up to VESA 400 x 400.
Also suitable for LED TVs.

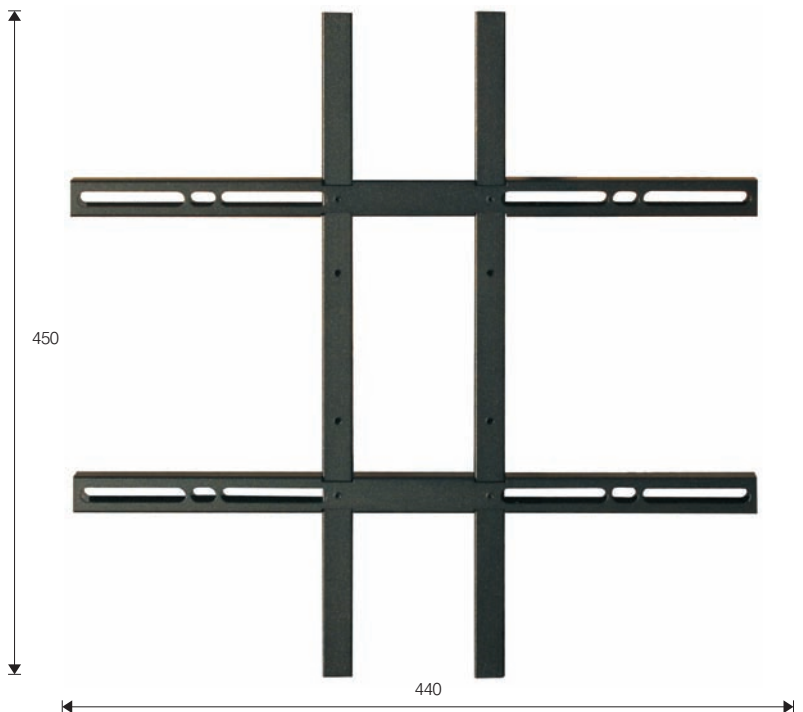

Projector supports

I supporti OMB dedicati ai proiettori sono il risultato di una ricerca mirata ad unire estetica e solidità. Le migliori performance e gli standard qualitativi più elevati sono assicurati da una meccanica collaudata, adatta anche ad apparecchi ad ottica ultra-corta

OMB's projector supports are the result of an exemplary research targeted at uniting aesthetics to solidity. High quality products and top performance are guaranteed by well-tested mechanics, suitable for appliances with ultra-short optics.

“

Per la mia azienda, avevo bisogno di un proiettore che potesse essere pronto all'uso ma collocato in una posizione discreta. Ero stufo di fili disordinati e proiettori si equilibrio sul tavolo. Così ho collocato un supporto della OMB sul soffitto in mezzo alla sala riunioni. Quando non serve, non c'è. Appena serve, è già pronto. E tutto rimane in ordine

For my company I needed a projector that was ready for use, but not in your face. I was fed up of seeing wires and projectors balancing on tables or piles of books. I positioned an OMB support in the centre of the ceiling of the conference room, so when it's not in use it can't be seen and when you need it it's ready and everything is so much tidier

”

Patrick, 38



15 kg max.
33 lbs max.

MONOPROJECTOR

3

col.

● 26080

Supporto universale da soffitto, snodato per videoproiettori.

Adjustable ceiling bracket for video projectors

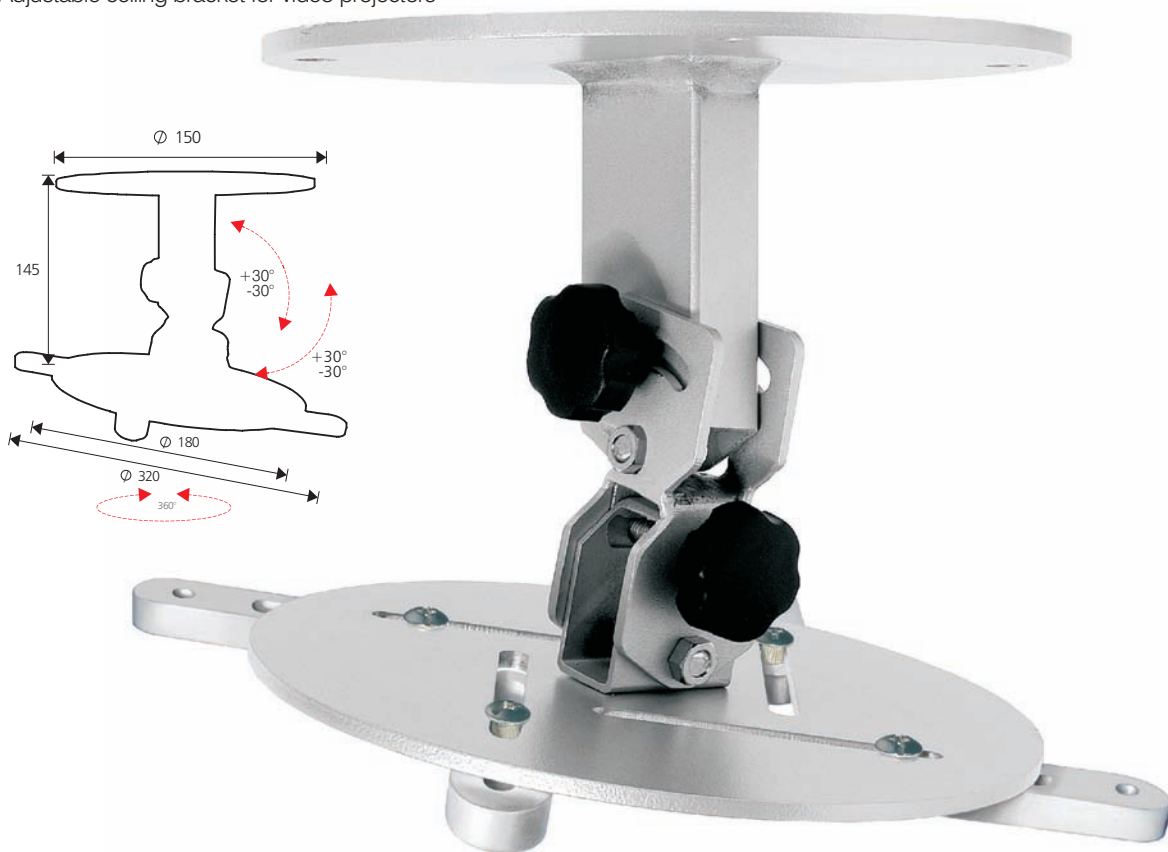

15 kg max.
33 lbs max.

EXTENSION 900 - 1700

● 26083 Regolabile da 900 a 1700mm / Adjustable from 900 to 1700mm



15 kg max.
33 lbs max.

EXTENSION 500 - 900

● 26082 Regolabile da 500 a 900mm / Adjustable from 500 to 900mm



15 kg max.
33 lbs max.

EXTENSION 300 - 500

● 26081 Regolabile da 300 a 500mm / Adjustable from 300 to 500mm

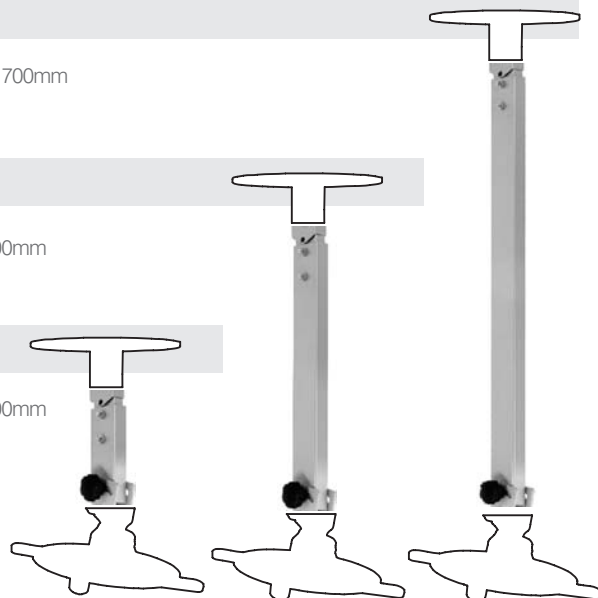

15 kg max.
33 lbs max.

PRECISION PROJECTOR

3

col.

● 26150

L'intuitivo sistema di regolazione micrometrica è supportato dalle quattro pratiche manopole incorporate che permettono al proiettore di rimanere nella posizione desiderata. La distanza da parete è regolabile.

The intuitive micrometric adjustment system provides 4 practical knobs to block the projector in the desired position. Lateral distance can be regulated.

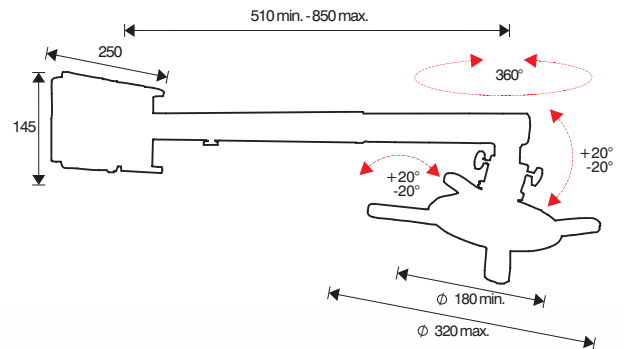
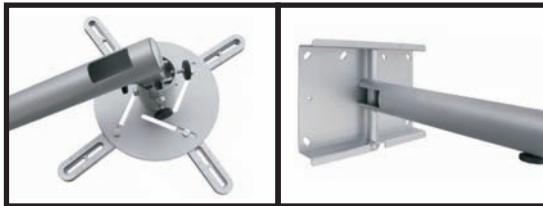
10 kg max.
22 lbs max.

PRECISION EXTENSION 800 - 1200

col.

● 26151 Regolabile da 800 a 1200mm. / Adjustable from 800 to 1200mm.

10 kg max.
22 lbs max.

PRECISION EXTENSION 1200 - 1600

col.

● 26152 Regolabile da 1200 a 1600mm. / Adjustable from 1200 to 1600mm.





20 kg max.
44 lbs max.

PROJECTOR BRACKET for SANYO XL 50A e XL51A

col.

16153



Supporto da parete adatto per videoproiettori di tipo Sanyo XL 50A e XL51A
La distanza dalla parete è regolabile manualmente ed il particolare meccanismo
consente sempre di livellare l'apparecchio nella posizione ottimale,
consentendo anche una leggera inclinazione.



A wall mount suitable for video projectors such as Sanyo XL 50A
and XL51A. The wall distance can be adjusted manually
and its distinctive mechanism permits even the slightest tilt.

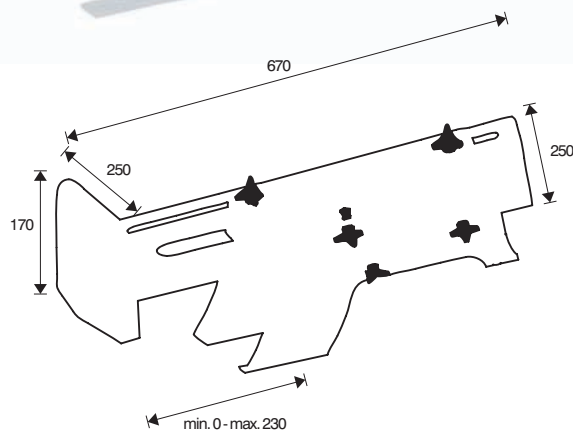
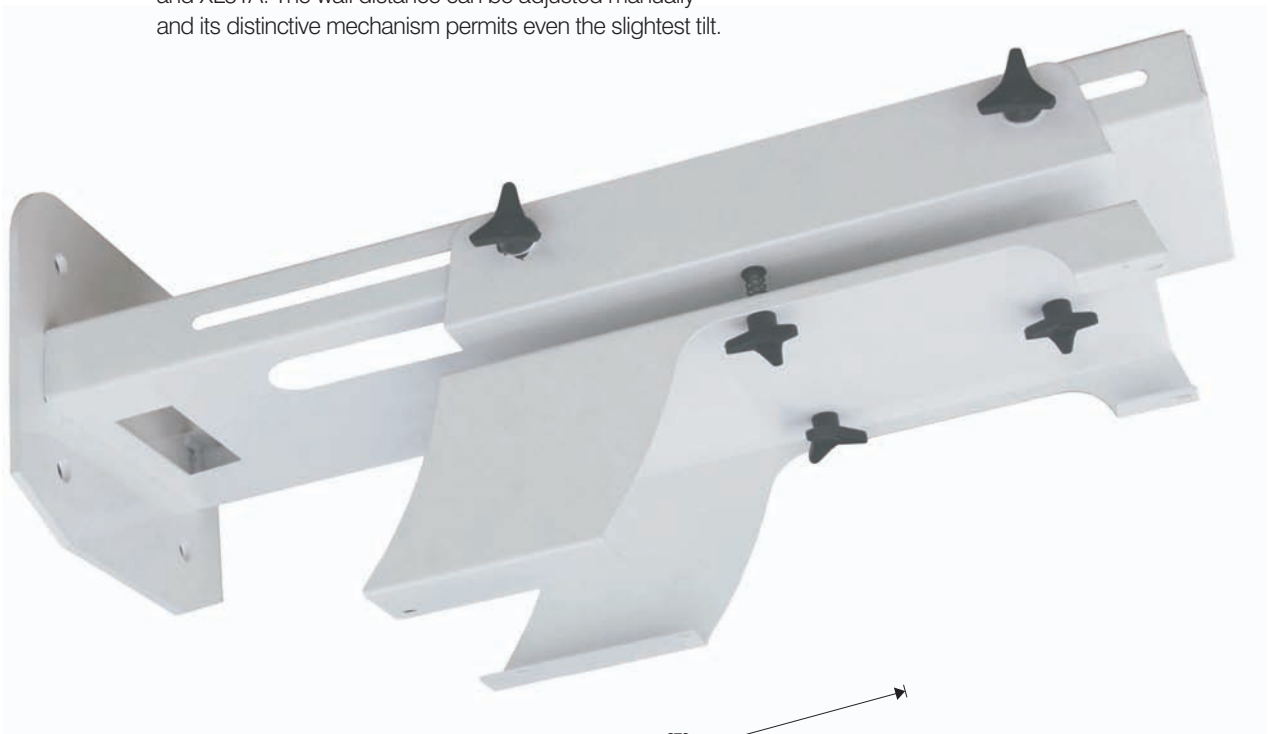

Classic TV supports

I supporti OMB dedicati alle televisioni Crt rappresentano il "classico" della nostra produzione. Sono stati i primi ed ancora intramontabili supporti per cambiare la collocazione della televisione dentro gli spazi delle abitazioni. Movimenti precisi, sicurezza, massima funzionalità; la linea "sfero" rappresenta ancor oggi l'insuperabile tradizione dei nostri supporti.

OMB's supports for Crt TVs are part of the "classic" production line. They were the first supports which permitted to change the position of the TV in a home. These evergreen supports are precise, safe and functional. The "sfero" line is still today testimonial of the unsurpassable tradition of OMB's supports.

“
Ero affezionata al mio vecchio televisore, ma non ho voluto rinunciare alla comodità dei supporti OMB.

I was fond of my old TV set, but I didn't want to give up the convenience of OMB's supports ”

Dolores, 31



14-19"
35-49cm



30 kg max.
66 lbs max.



MONOSFERO 30



col. 06024 col. 26024

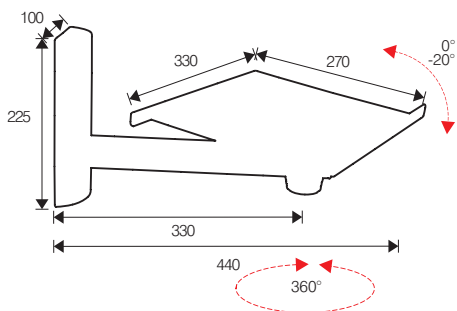

Supporto murale ad uno snodo, inclinabile per tv o monitor di piccole e medie dimensioni.

Inclinable wall bracket with one articulation for small or medium TVs or monitors.



19-25"
49-63cm



50 kg max.
110 lbs max.



MONOSFERO 50



col. 06025 col. 26025

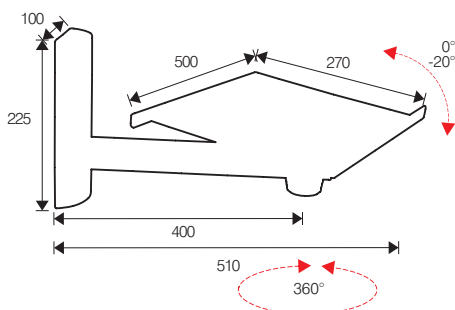

Supporto murale ad uno snodo, inclinabile per tv o monitor di piccole e medie dimensioni.

Inclinable wall bracket with one articulation for small or medium TVs or monitors.



19-21"
49-53cm



30kg max.
66 lbs max.



BISFERO 30

2

col. 06031 col. 26031

Supporto murale a due snodi, inclinabile per tv o monitor di piccole e medie dimensioni.

Inclinable wall bracket with two articulations for small or medium TVs or monitors.

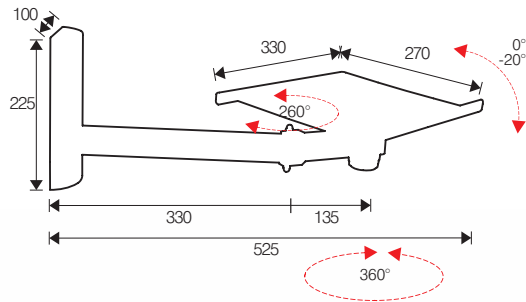

21-25"
53-63cm



50 kg max.
110 lbs max.



BISFERO 50

2

col. 452026 col. 252026

Supporto murale a due snodi, inclinabile per tv o monitor di medie dimensioni.

Inclinable wall bracket with two articulations for medium sized TVs or monitors.

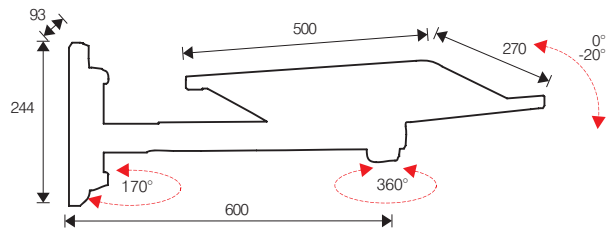

...and for the kitchen

MICRO



60 kg max.
132 lbs max.

- col. 17060 col. 27060

Supporto murale pieghevole e regolabile per forni a microonde.

An adjustable wall bracket for micro-wave ovens.

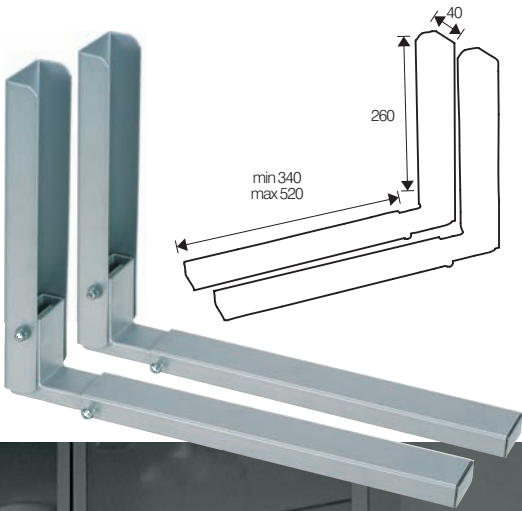
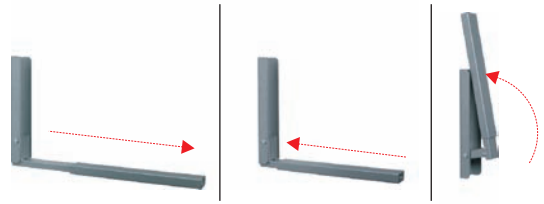

Electric supports

New LED, LCD Plasma supports

The ultimate design

More LED, LCD Plasma supports

Projector supports

Classic TV supports

Audio supports

Surfaces

Audio supports

I supporti audio della OMB sono a servizio di chi vuole sentire la musica in tutta la sua potenza. Inoltre con Punto, Ulysses e New-flex, i supporti sono pronti da installare, sicuri e perfetti. Diffondono il suono nei diversi ambienti con la massima qualità

The audio supports of OMB have been specially designed for those who wish to listen to music at the ninth power. Furthermore, with Punto, Ulysses and New-flex, the supports are ready to be mounted, safe and perfect. They diffuse top quality sound anywhere.

“

Volevo sentire i concerti come quando ero direttore d'orchestra. Tutte le soluzioni non mi soddisfacevano, finché ho sperimentato i supporti audio della OMB... ed è stata subito l'emozione di una prima a teatro.

I wanted to relive the audio sensations I had when I was a conductor. but I just couldn't find the right solution, until I tried OMB's audio supports.....and I had the same emotion as I did at a premiere at the theatre

”

Anthony, 74



5 kg max.
11 lbs max.

NEW FLEX



col. 04041 col. 24041

Supporto da parete e soffitto per casse acustiche con rotazione ed inclinazione.

A wall and ceiling bracket for loudspeakers which can be swivelled and tilted.

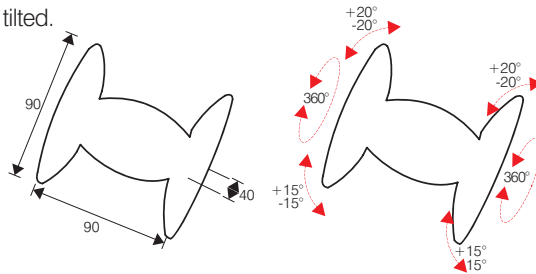

5 kg max.
11 lbs max.

NEW FLEX + ADAPTOR



col. 04042 col. 24042

Adattatore per casse piccole
Adaptor for small speakers



20kg max.
44 lbs max.

ULYSSES



col. 04032 col. 24032
min 270 max 400

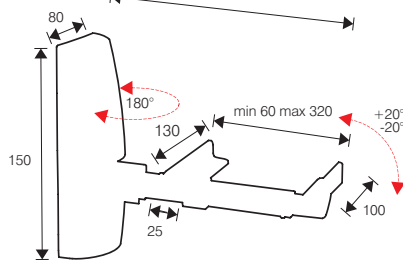

Supporto da parete per casse acustiche con possibilità di rotazione ed inclinazione.

Revolving and inclinable wall bracket for loudspeakers.



25 kg max.
55 lbs max.

PUNTO



col. 04040 col. 24040

Supporto da parete per casse acustiche con possibilità di rotazione ed inclinazione.

Revolving and inclinable wall bracket for loudspeakers.

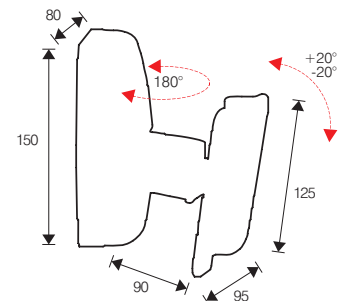

Electric supports

New LED, LCD Plasma supports

The ultimate design

More LED, LCD Plasma supports

Projector supports

Classic TV supports

Audio supports

Surfaces

Surfaces

I supporti per superfici della OMB sono caratterizzati da una semplice praticità per avere soluzioni immediate, efficaci e alla portata di tutti

OMB's surface supports are practical and functional which make life better and simpler.

“

Adoro gli ambienti openspace. E con i supporti rotanti della OMB posso girare la televisione nella direzione dei diversi spazi della mia abitazione: per quando cucino, per quando lavoro, per quando mi rilasso sul divano

I love open space designs and with OMB's rotating supports I can turn the Tv in whichever direction I want, towards the kitchen when I cook, towards the studio when I work or towards the lounge area for when I want to relax on the sofa ”

Asami, 76



29"
75 cm

SLIMLINE

col.
● 05030

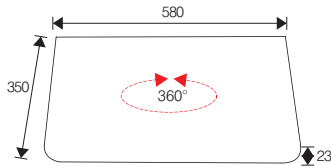

Supporto rotante in legno per tv.
Rotating wooden plane for TVs.



60 kg max.
132 lbs max.



29"
75 cm

LIBERTY

col. ● 05010 col. ● 25010

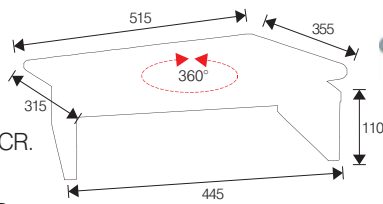

Supporto rotante in legno
per tv con spazio per DVD o VCR.
Rotating wooden plane for
TVs with space for DVD or VCR.



60 kg max.
132 lbs max.



29"
75 cm

DOUBLE

col. ● 05011 col. ● 25011

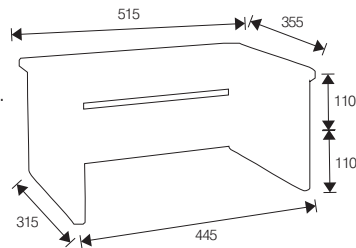

Supporto in legno per tv
con doppio spazio per DVD o VCR.
Wooden plane for TVs with
double space for DVD or VCR.



60 kg max.
132 lbs max.



60 kg max.
132 lbs max.

CIRCLE

col.
● 05031

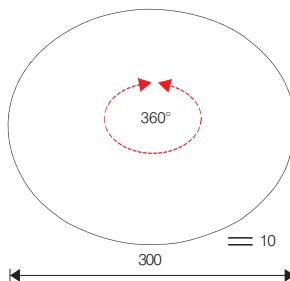

Supporto rotante
in plastica per tutte le tv.
Rotating plastic plane for TVs.

www.ombitaly.it



creating space beautifully



AUDIO VIDEO SUPPORTS



DISTRIBUTED BY:

WES Australasia Pty Ltd.

138 Liverpool Road, Ashfield, NSW, 2131

Phone: 02-9797-9866 Fax: 02-9716-6015

Email: sales@wes.net.au Web: www.wes.net.au